

FLOATING PUMP INLETS

Model Numbers: **FI-42**
FI-50

DEPEND ON
DAVEY

WATER PRODUCTS



RAINWATER ACCESSORIES

PRODUCT DESCRIPTION

Floating inlets for drawing water from just below the surface where the highest quality, cleanest water lies.

APPLICATIONS

- Rainwater harvesting
- Suitable for above & below ground tanks
- Suitable for use with D42A/B, HS & HP pumps
- Ideal accessory for RainBank® installations

FEATURES & BENEFITS

Fine mesh of 1.2mm on the inlet screen sleeve will reduce entry of fine debris and suspended particles into the pump and rainwater harvesting system, protecting the pump and plumbing from blockage and reducing wear.

Sealed 150mm floating ball, keeps the water inlet approximately 200mm below the surface of the water, only drawing the cleanest water available.

1 or 2m long food quality reinforced plastic hose that is tangle or kink resistant. Contains bio-static compounds to resist biological growth.

FI-42 features a tough polyethylene plastic base that fits firmly to the base of a Davey D42A/B submersible pump. This combination is ideal for installing the pump inside a rainwater tank, dam or pumping station.

FI-50 features an in-built check valve to maintain pump prime.

OPERATING LIMITS

Maximum flow rate	40lpm
Maximum water temperature	50°C
Minimum water temperature	1°C
Inlet size	1"
Outlet size	1" M (FI-50 only)
Check valve size	1" (FI-50 only)

2 YEAR
WARRANTY

H/O & MFG SCORESBY
Quality System

Quality
Endorsed
Company
ISO 9001 Lic 10636

TECHNICAL SPECIFICATIONS

MATERIALS OF CONSTRUCTION

PART	MATERIAL
Float	Polyethylene
Screen	300 series stainless steel
Check valve	Brass
Hose	PVC food quality
Hose clips	300 series stainless steel
Pump base	Polyethylene

TYPICAL APPLICATION

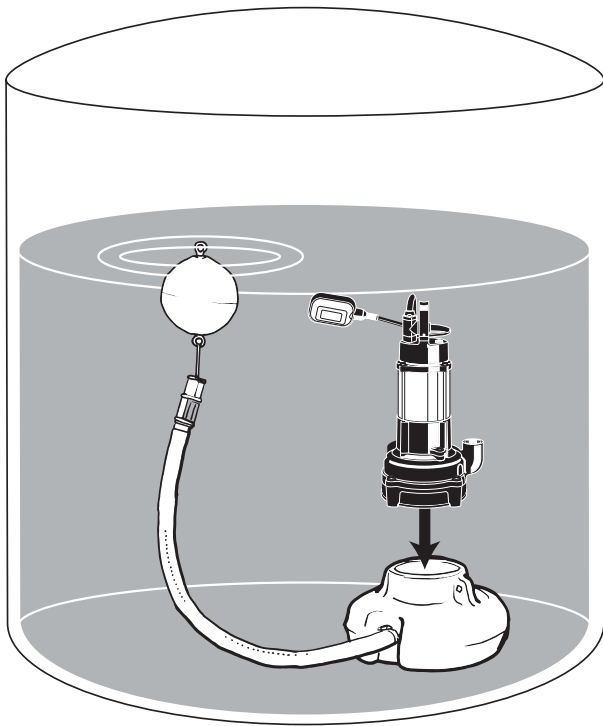

DIMENSIONS

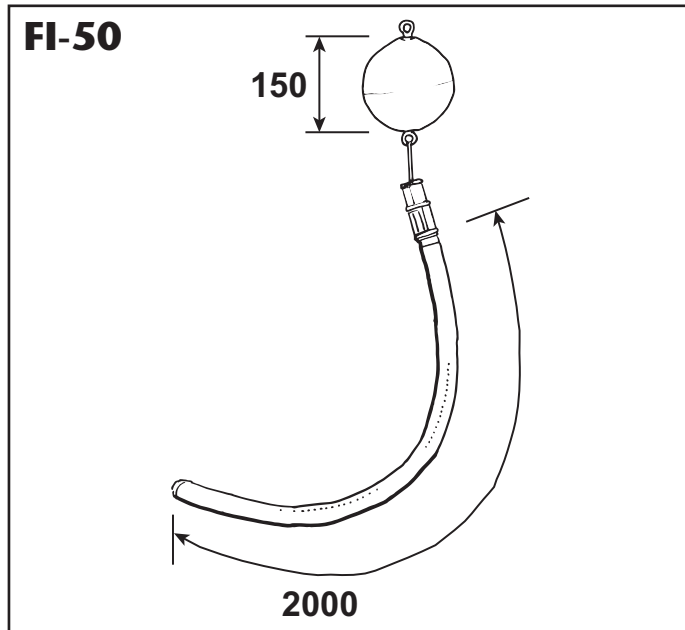
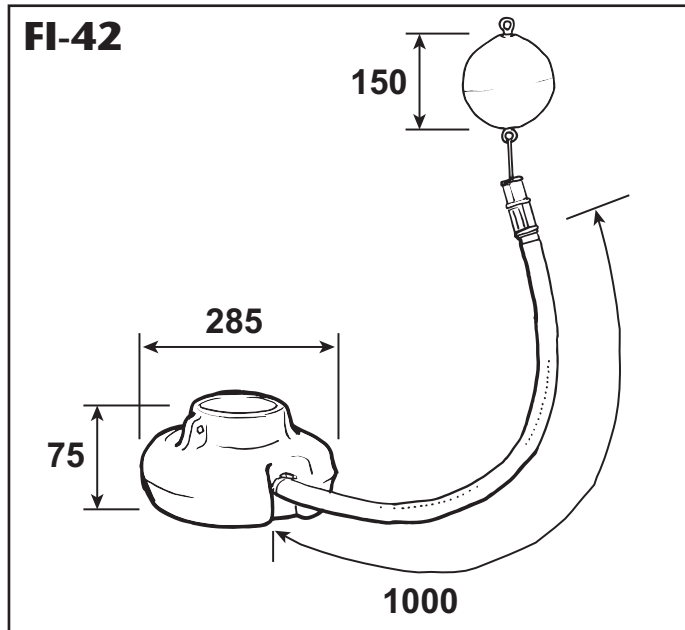

All dimensions in mm unless otherwise stated.

This literature is not a complete guide to product usage. Further information is available from your Davey dealer, Davey Customer Service Centre and from the relevant product Installation and Operating Instructions. This data sheet must be read in conjunction with the relevant product Installation and Operating Instructions and all applicable statutory requirements. Product specifications may change without notice.

© Davey and RainBank are registered trademarks of Davey Water Products Pty Ltd. © Davey Water Products Pty Ltd 2006.



Visit Davey on-line for further information
davey.com.au

DEPEND ON
DAVEY

WATER PRODUCTS

Davey Water Products Pty Ltd International

Member of the GUD Group
ABN 18 066 327 517
Head Office and Manufacturing
6 Lakeview Drive,
Scoresby, Australia 3179
Ph: +61 3 9730 9222
Fax: +61 3 9753 4100
Website: davey.com.au
Customer Service Centre
Ph: 1300 367 866
Fax: 1300 369 119
E-mail: sales@davey.com.au
Interstate Offices
Sydney • Brisbane • Adelaide
Perth • Townsville

6 Lakeview Drive,
Scoresby, Australia 3179
Ph: +61 3 9730 9121
Fax: +61 3 9753 4248
E-mail: export@davey.com.au

Germany
Kantstrasse 53,
04275 Leipzig
Ph: +49 341 301 0412
Fax: +49 341 301 0413
E-mail: akrenz@daveyeurope.com

New Zealand
7 Rockridge Avenue,
Penrose, Auckland 1330
Ph: +64 9 570 9135
Fax: +64 9 527 7654
Website: daveynz.co.nz
E-mail: sales@daveynz.co.nz

USA - Davey Pumps Inc.
1005 N. Commons Drive
Aurora, Illinois 60504
Ph: +1 630 898 6976
Fax: +1 630 851 7744
Website: daveyusa.com
E-mail: sales@daveyusa.com