

## TANK LEVEL GAUGES

Model Numbers: **5000555 Mechanical**  
**5000500 Pneumatic**

DEPEND ON  
**DAVEY**

## WATER PRODUCTS

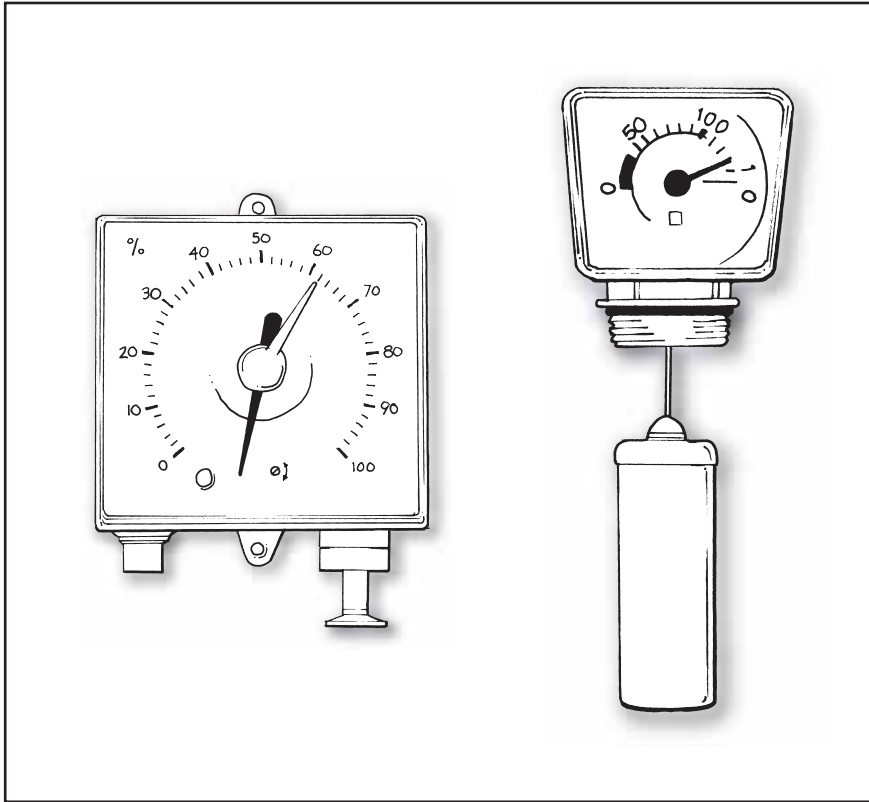

## RAINWATER ACCESSORIES

### PRODUCT DESCRIPTION

Simple and reliable water level indicators for domestic rainwater tanks.

### APPLICATIONS

Ideal for :-

- Domestic rainwater systems
- Water level indicators in sumps or pits
- Above and below ground rainwater tanks

### FEATURES & BENEFITS

Tank level gauges allow you to keep a close eye on your precious water stores without providing access for vermin or light to enter your water storage tank.

Mechanical tank mounted gauge provides a simple and reliable indication of the height in centimetres of the water that you have remaining in your water storage tank.

Pneumatic wall mount gauges provide a remote indication of the height of the water that you have remaining in your water storage tank. Measurement increments are in percentage of full %.

Both gauges are simple to install and adjust to ensure an accurate level reading.

Long life corrosion resistant internal components and non contaminating water contact components.

### OPERATING LIMITS

Depth measurement	
Mechanical gauge	0 - 1.5m or 0 - 2.5m
Pneumatic gauge	1 - 3.0m
Maximum distance from tank	
Mechanical gauge	Must be tank mounted
Pneumatic gauge	Comes with 10m capillary hose Extendable to 50m
Maximum water temperature	50°C
Minimum water temperature	1°C
Maximum ambient temperature	50°C
Mounting hole	
Mechanical gauge	47mm threaded
Pneumatic gauge	5mm for capillary tube

# TECHNICAL SPECIFICATIONS

## MATERIALS OF CONSTRUCTION

PART	MATERIAL
<b>Mechanical gauge</b>	
Gauge body	ABS
Screen	Polycarbonate
Tank probe	Polyethylene
Cord	Nylon
Weight	Water filled polypropylene
Oring	Nitrile rubber
<b>Pneumatic gauge</b>	
Gauge body	ABS
Screen	Polycarbonate
Capillary tube	PVC

## DIMENSIONS

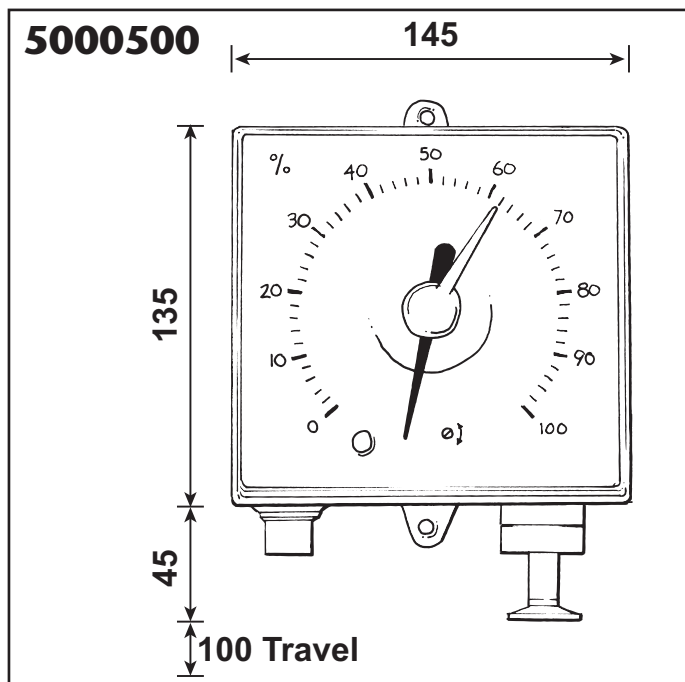
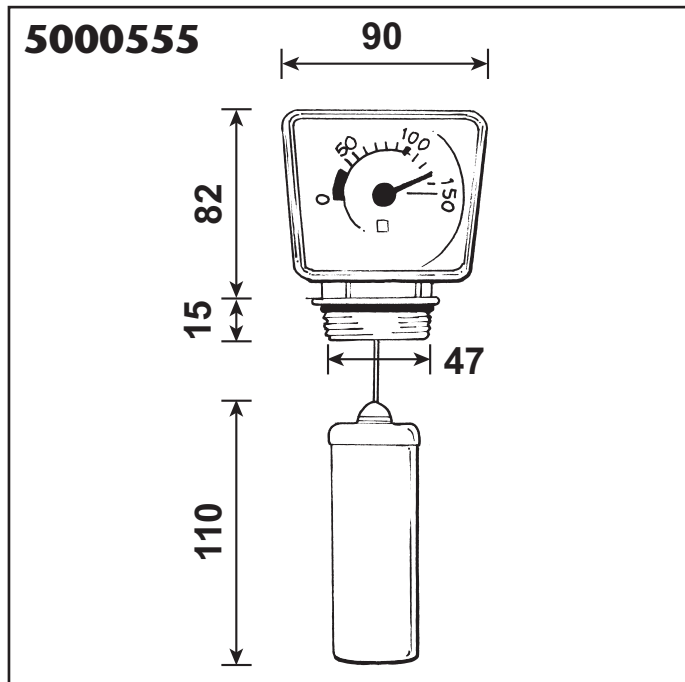

All dimensions in mm unless otherwise stated.

This literature is not a complete guide to product usage. Further information is available from your Davey dealer, Davey Customer Service Centre and from the relevant product Installation and Operating Instructions. This data sheet must be read in conjunction with the relevant product Installation and Operating Instructions and all applicable statutory requirements. Product specifications may change without notice.

© Davey and RainBank are registered trademarks of Davey Water Products Pty Ltd. © Davey Water Products Pty Ltd 2006.



Visit Davey on-line for further information  
[davey.com.au](http://davey.com.au)

DEPEND ON  
**DAVEY**

**WATER PRODUCTS**

### Davey Water Products Pty Ltd International

Member of the GUD Group  
**ABN 18 066 327 517**  
**Head Office and Manufacturing**  
6 Lakeview Drive,  
Scoresby, Australia 3179  
Ph: +61 3 9730 9222  
Fax: +61 3 9753 4100  
Website: [davey.com.au](http://davey.com.au)  
**Customer Service Centre**  
Ph: 1300 367 866  
Fax: 1300 369 119  
E-mail: [sales@davey.com.au](mailto:sales@davey.com.au)  
**Interstate Offices**  
Sydney • Brisbane • Adelaide  
Perth • Townsville

6 Lakeview Drive,  
Scoresby, Australia 3179  
Ph: +61 3 9730 9121  
Fax: +61 3 9753 4248  
E-mail: [export@davey.com.au](mailto:export@davey.com.au)

**Germany**  
Kantstrasse 53,  
04275 Leipzig  
Ph: +49 341 301 0412  
Fax: +49 341 301 0413  
E-mail: [akrenz@daveyeurope.com](mailto:akrenz@daveyeurope.com)

**New Zealand**  
2 Rothwell Avenue,  
North Harbour, Auckland 1330  
Ph: +64 9 914 3680  
Fax: +64 9 914 3685  
Website: [daveynz.co.nz](http://daveynz.co.nz)  
E-mail: [sales@daveynz.co.nz](mailto:sales@daveynz.co.nz)

**USA**  
**Davey Pumps Inc.**  
1005 N. Commons Drive  
Aurora, Illinois 60504  
Ph: +1 630 898 6976  
Fax: +1 630 851 7744  
Website: [daveyusa.com](http://daveyusa.com)  
E-mail: [sales@daveyusa.com](mailto:sales@daveyusa.com)