



DOSATRON®

20 m³/h

WATER POWERED DOSING TECHNOLOGY

D 20 S - 0.2 - 2 %

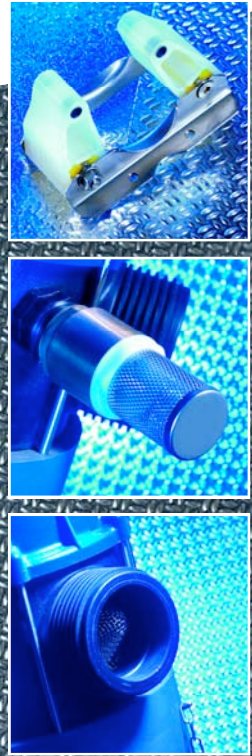

SPECIFICATIONS

- Injection Range : **0.2 - 2 %**
[1 : 500 - 1 : 50]
 - Water flow range* : **1 - 20 m³/h**
[16.66 - 333.3 l/mn]
[5 - 100 US GPM]
 - Operating pressure : **0.12 - 10 bar**
[2 - 120 PSI]
 - Concentrated additive injection : **2 - 400 l/h**
[0.009 - 1.75 US GPM]
- * For operating unit with other fluids than water, please contact us

A unique technology associating all dosing functions

Dosing Technique :

Non-electric proportional

Energy Source :

Water flow and pressure

Integrated functions :

- **Metering** : volumetric hydraulic motor
- **Injecting** : continuous proportional injection of liquid or soluble concentrate
- **Regulating** : proportionality servo-controlled by the water flow
- **Mixing** : integrated mixing

Package contents :

- 1 Dosatron, 1 wall bracket,
- 1 Suction tube 175 cm [69"]
- Ø 6 X 9 mm [1/4" id X 3/8"od]
- 1 Owner's manual.



20 m³/h - 0.2 - 2 %

Operating principle

Installed directly in the water supply line, the Dosatron operates by using the flow of water as the power source. The water activates the Dosatron, which takes up the required percentage of concentrate directly from the container and injects it into the water. Inside the Dosatron, the concentrate is mixed with the water, and the water pressure forces the solution downstream. The dose of concentrate will be directly proportional to the volume of water entering the Dosatron, regardless of variations in flow or pressure, which may occur in the main line.

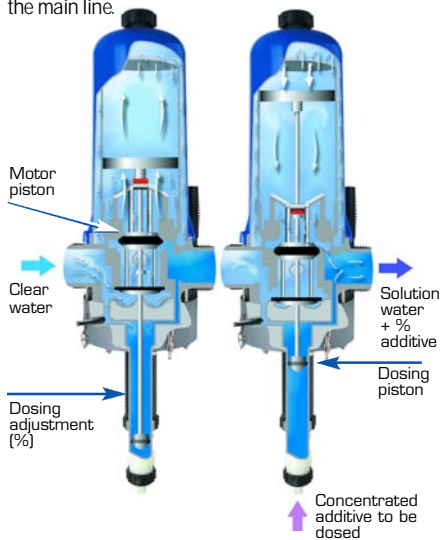

Proportional injection externally adjustable



Partially unscrew the black nut. Turn the dosing stem. Put the chosen rate on the black mark of the transparent

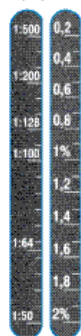

ring. The amount of injected concentrate is proportional to the amount of water coming into the Dosatron: i.e. Adjustment at 1% = 1:100 = 1 Volume of concentrate into 100 Volumes of water.

Dosatron, a complete range

Dosatron develops, manufactures and markets a unique dosing technology that allows any liquid or soluble concentrate to be continuously and proportionally injected and mixed into water.

The 20 m³/h range

REF.	DOSAGE	PRESSURE
ADJUSTABLE		
D 20 S	0.2 - 2 %	0.12 - 10 bar

Other product lines available to treat water flows up to 1.5 m³/h, 2.5 m³/h, 4.5 m³/h, 8 m³/h, 30 m³/h, 60 m³/h, ...
For special models, accessories and particular systems: please consult us.

Specifications

General	
- Maximum operating water temperature :	40° C [104° F]
- Minimum operating water temperature :	5° C [41° F]
- Dosing rate :	i.e. Adjustment at 1 % = 1:100 = 1 V concentrate into 100 V water
- Average dosing accuracy :	+/- 5 % (Charts on demand)
- Repeatability :	+/- 3 % (API standard)
- Pressure loss :	0.12 - 0.88 Bar [1.74 - 12.76 PSI] (depending on operating conditions)
Other integrated functions	
- Internal motor filter :	inlet filter
- Inlet/Outlet :	compression adaptors 2" M Ø 50 x 60 mm rings, adaptors and seals supplied
- Built-in by-pass :	yes
- Built-in airbleeder :	yes
- Built-in anti-siphon device :	yes
Motor	
- Motor :	double action hydraulic piston
- Motor capacity :	~ 5 l [1.32 US Gallons] (1 cycle)
- Mixing chamber :	yes
Dosage	
- Injection :	pre-dilution at the outlet
- Dosing plunger :	simple action, injection on the upstream
- Injection check valve :	double check-valve
Suction	
- Self-priming :	yes
- Maximum viscosity of concentrate :	400 cSt at 20°C [68 ° F]
- Maximum vertical or horizontal suction of the concentrate :	4 m [13 ft]
- Strainer :	yes - foot strainer

Markets

Environment - Hygiene - Water treatment - Vehicle wash - Metal processing - Food processing - Graphic Arts - Horticulture - Livestock...

Principal applications :

Medication - Disinfecting - Cleaning - Fertilization - Phytosanitation - Supplementation - Lubrication - PH/TH Correction - Sanitation - Flocculation - Vehicle wash...

Installation

Regulations : Refer to local water regulations, prior to installing your Dosatron.

To optimize your Dosatron, we advise to :

- Install a filter (300 mesh [60 microns]) upstream, depending on your water quality.
- Change the dosing seals once a year.
- Rinse as often as possible with clear water.
- Turn off the water supply and allow the pressure to drop to zero before adjusting the injection rate.
- Install necessary protections for excess flow, excess pressure and water hammer (anti-hammer flow/pressure device).
- Install your Dosatron on a total by-pass line.

For all other installation advice, please consult us.

Size :

- Package size : 100 X 43 X 34 cm [40" X 17" X 14"]
- Package weight : 23 kg [~ 50.7 US lbs]

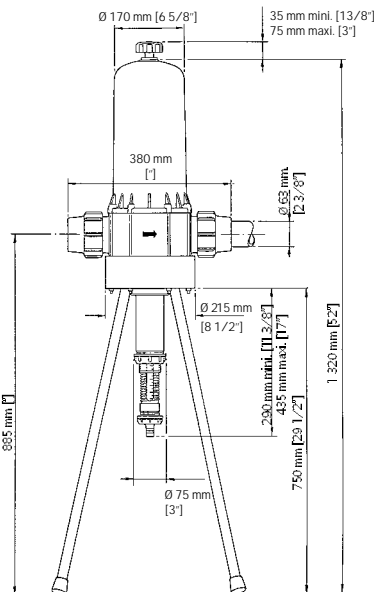

Standard material

- Housing : polypropylene, PVC, Aluminium
- Motor piston : polypropylene, polyamide, EPDM, stainless steel
- Injection area : polypropylene, polyethylene, PVC
- Injection hose : PVC reinforced

Available options

(■ : Option ● : standard ★ : not available for this model)

Optimized compatibility

- AF : Recommended seals for alkaline concentrate
- VF : Recommended seals for acid concentrate
- ★ PVDF : Housing
- ★ H : Hastelloy plunger rod
- ★ IE : External injection
- ★ V : Kit for viscous concentrate
- ★ Injection hose : Special material hose and foot strainer available

BSP



NPT



Adaptors.

Optimized installation

- BP : integrated by-pass
- Other fittings
- ★ Strap
- Support legs
- Other : please contact us



Integrated by-pass : allowing turning concentrate injection on and off.

These options allow adapting your Dosatron to your needs. Contact our technical service to help determine what option you may need.

Each Dosatron unit is factory tested.

Netafim Australia

213-217 Fitzgerald Rd - Laverton, Vic 3026 t: (03) 8331 6500 f: (03) 9369 3865 www.netafim.com.au netinfo@netafim.com.au

Netafim New Zealand

13a Aintree Ave - Airport Oaks, Auckland 2022 t: (09) 256 2551 f: (09) 256 2552 www.netafim.co.nz auckland@netafim.co.nz