

ODIS

IRRIGATION EQUIPMENT LTD.

GRAVEL/ SAND FILTERS SERIES 4000

APPLICATIONS

- Used as a Primary Filter for water from open reservoirs and recycled water.
- Most effective for filtration of water heavily contaminated with algae and organic matter.



ODIS Filtration *is The Heart* of Every Irrigation System

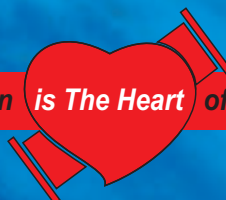

DESCRIPTION

A media filter uses gravel (or sand) as a bed that captures the suspended matter in the water flowing through.

Media filters are particularly effective for filtering algae, organic matter and recycled water. Odis media filters (series 4000) use a unique design of a double bottom chamber, divided by a welded reinforced steel plate.

The upper chamber contains the gravel (or sand) media, the lower chamber is empty and collects the filtered water.

The plate is covered by "mushroom" diffusers which are plastic, slotted conical units. They disperse the water uniformly, using effectively the whole media volume avoiding the occurrence of channeling or caking when operated correctly. This filter is particularly suitable for backflushing - a process involving the reversal of the water flow, causing a turbulent expansion of the media as a fluidised bed.

This flushes out the entrapped debris effectively.

After the backflushing is completed, the filter resumes its normal filtering mode as clean as a new filter.

The backflushing process can be activated manually or automatically by controller or computer.

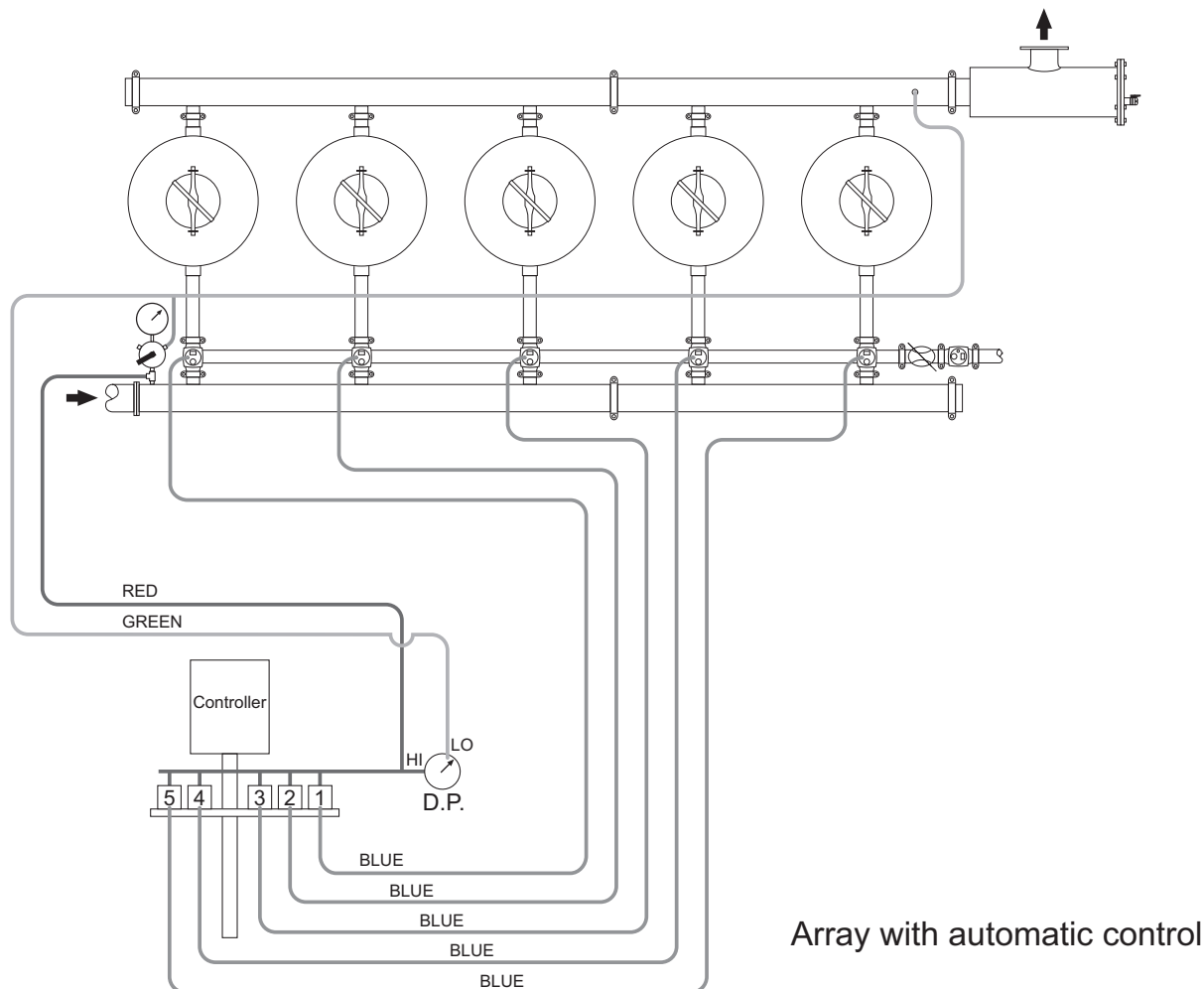

Available in the following inlet sizes: 1", 1½", 2", 3", 4".

Available in the following body diameters: 12", 16", 20", 24", 30", 36", 48", 60"

Filters of diameters 36", 48" and 60" are available in two options:

A. Top vertical inlet and horizontal outlet (short legs).

Models: 4363 (3"), 4484 (4"), 4604 (4").

B. Top vertical inlet and vertical outlet (long legs).

Models: 4363U (3"), 4484U (4"), 4604U (4").

Available with three end connections: Thread (M), Flange (F), Victaulic (V).

The filter has a 100 micron protective coating of extra durable polyester applied electrostatically and oven cured on a zinc-phosphate layer for maximal anti-corrosion protection.

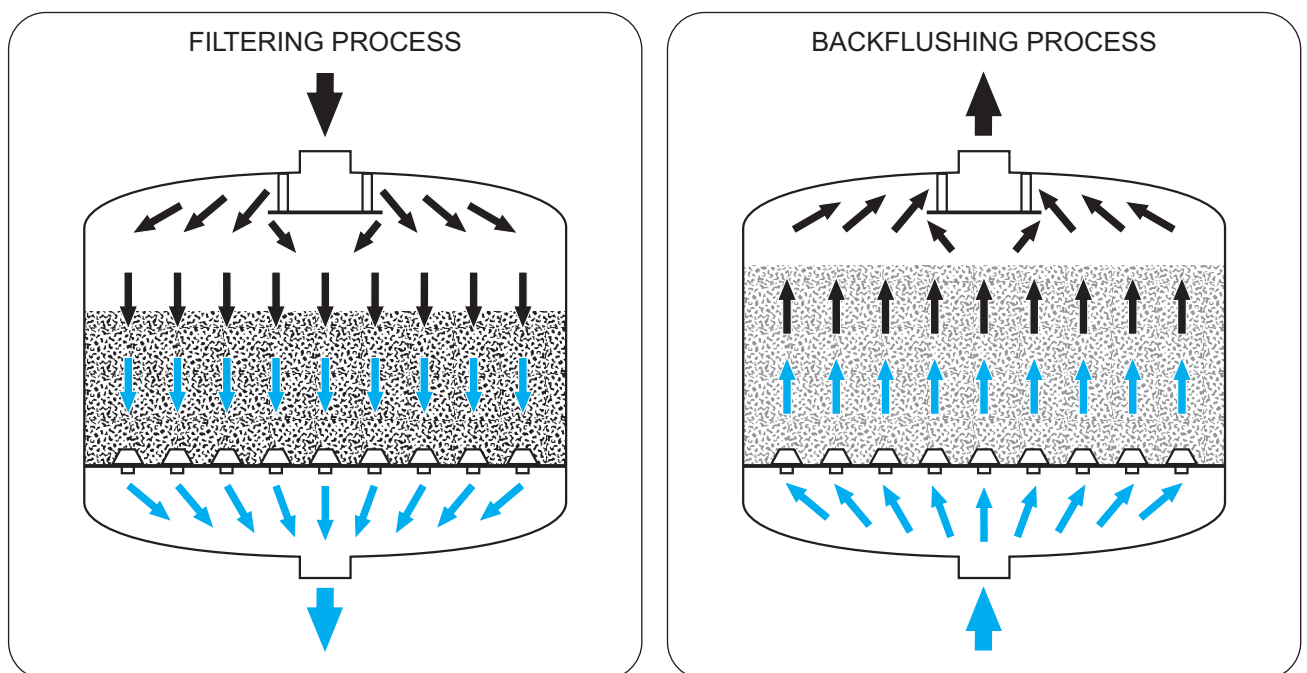

Dimensions & Weight
Metric Units

Model	B		D	H	H1	H2	Weight
	mm	inch	inch	mm	mm	mm	kg
4121	25	1"	12"	1150	775	120	42
4162 *	40	2"	16"	1250	870	180	50
4202	50	2"	20"	1250	870	180	70
4203	80	3"	20"	1400	1040	180	75
4242	50	2"	24"	1350	950	260	90
4243	80	3"	24"	1350	950	260	90
4303	80	3"	30"	1080	-	270	135
4363	80	3"	36"	1100	-	270	185
4484	100	4"	48"	1100	-	270	310
4604	100	4"	60"	1330	-	400	430
4363U	80	3"	36"	1325	-	390	200
4484U	100	4"	48"	1435	-	455	330
4604U	100	4"	60"	1890	-	650	460

* Available with 1½" Inlet Outlet (Model 41615).

U.S. Units

Model	B	D	H	H1	H2	Weight
	inch	inch	inch	inch	inch	lbs
4121	1"	12"	45	30.5	4.7	90
4162 *	2"	16"	49	34.7	7	110
4202	2"	20"	49	34.7	7	155
4203	3"	20"	55	41	7	165
4242	2"	24"	53	37.5	10.2	200
4243	3"	24"	53	37.5	10.2	200
4303	3"	30"	43	-	10.7	300
4363	3"	36"	43	-	10.7	400
4484	4"	48"	43	-	10.7	680
4604	4"	60"	52	-	16	950
4363U	3"	36"	52	-	15.2	440
4484U	4"	48"	57	-	18	730
4604U	4"	60"	75	-	25.5	1015

* Available with 1½" Inlet Outlet (Model 41615).

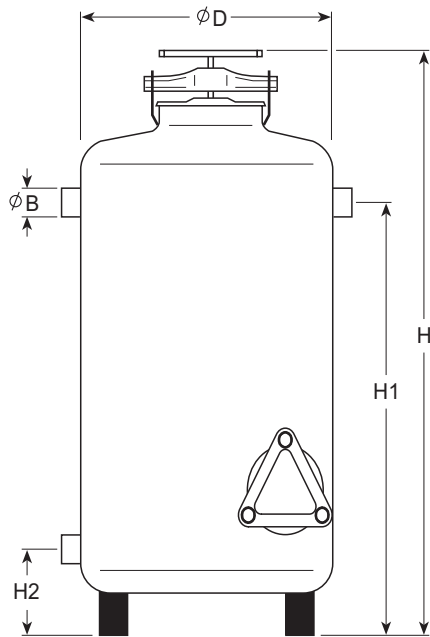

Models
4121, 41615, 4162, 4202, 4242, 4243

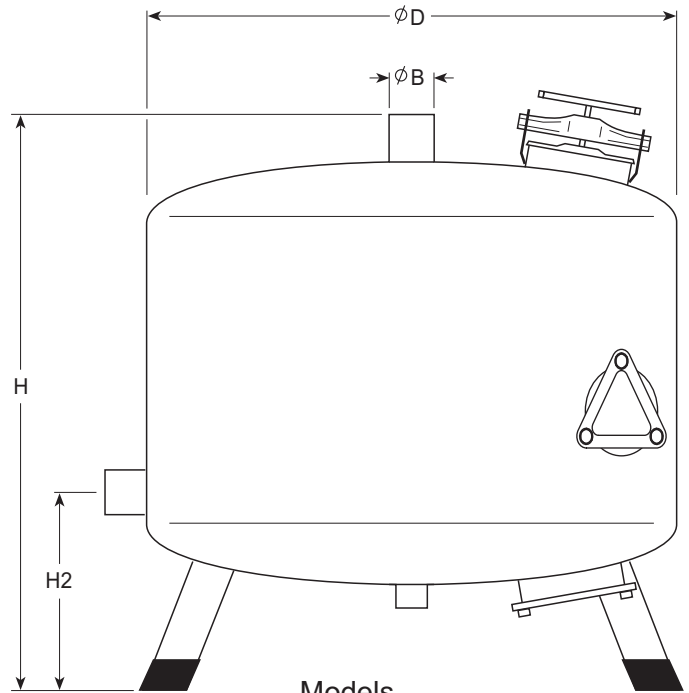

Models
4303, 4363, 4484, 4604

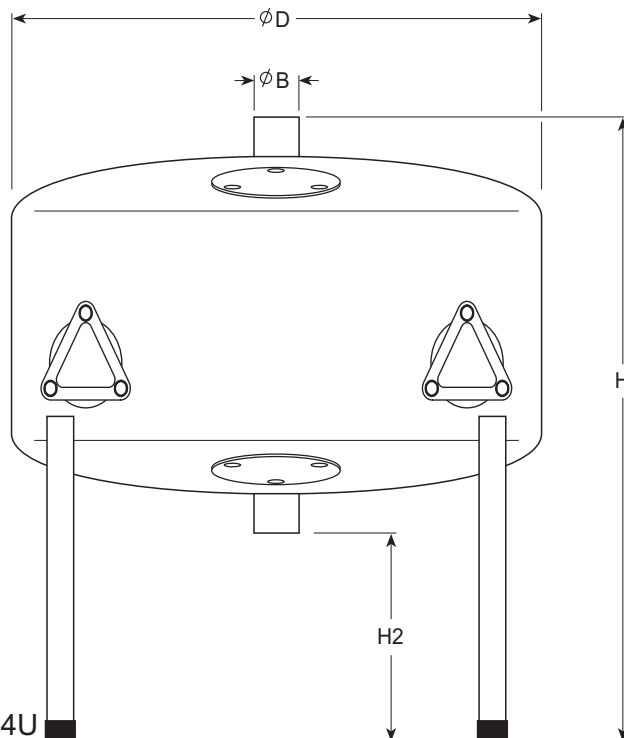

Models
4363U, 4484U, 4604U

Recommended Flow Rates

Metric Units/ U.S. Units

Models	Inlet / Outlet Diameter		Body Diameter		Recommended Flow Rate ***							
					Minimum		Average *		Maximum		Back Flushing	
	inch	mm	inch	mm	m ³ /h	U.S. gpm	m ³ /h	U.S. gpm	m ³ /h	U.S. gpm	m ³ /h	U.S. gpm
4121	1"	25	12"	300	3.5	15	5	22	6	26	7	31
** 4162	2"	40	16"	400	6	26	8	35	11	48	10	44
4202	2"	50	20"	500	9	40	12	53	18	80	15	66
4203	3"	80	20"	500	10	44	12	53	18	80	15	66
4242	2"	50	24"	600	14	62	20	88	28	123	25	110
4243	3"	80	24"	600	14	62	20	88	28	123	25	110
4303	3"	80	30"	750	21	92	30	132	42	185	38	167
4363	3"	80	36"	900	32	141	42	185	62	273	54	238
4484	4"	100	48"	1200	62	273	72	317	120	528	95	418
4604	4"	100	60"	1500	80	352	110	485	150	660	150	660
4363U	3"	80	36"	900	32	141	42	185	62	273	54	238
4484U	4"	100	48"	1200	62	273	72	317	120	528	95	418
4604U	4"	100	60"	1500	80	352	110	485	150	660	150	660

- * Average water quality. For dirty water reduce the flow rate.
- ** Available with 1 1/2" Inlet Outlet (Model 41615).
- *** For crushed basalt no. 1 or crushed granite no. 11.
(For crushed silica or quartz sand no. 16, use half flow rates).

Technical Data

- Media Filter uses gravel (or sand) for depth filtration.
- Double bottom chamber with "mushroom" diffusers for efficient filtration and backflushing.
- Minimum media size: 0.6 mm.
- After backflushing, filter resumes its normal filtering mode as a new filter.
- Max. recommended working pressure: 8 bar (120 psi).
- Max. pressure: 10 bar (150 psi).
- Horizontal inlet/outlet, Models: 4121(1"), 41615(1 1/2"), 4162(2"), 4202(2"), 4203(3"), 4242(2"), 4243(3").
- Top vertical inlet/horizontal outlet (short legs), Models: 4303(3"), 4363(3"), 4484(4"), 4604 (4").
- Top vertical inlet/bottom vertical outlet (long legs), Models: 4363U(3"), 4484U(4"), 4604U (4").
- Rubber coated metal legs isolate the filter from the ground to prevent corrosion and damage to the protective coating.
- Large service openings for inspection and service.
- Modular design particularly suitable for flexibility in assembly of arrays for various flow rates.

Protective Coating

100 micron extra-durable polyester, applied electrostatically and oven-cured on a zinc-phosphate layer for maximal anti-corrosion protection.

Pressure Relief Valve

A pressure relief valve must be inserted before the filtering installation if pressure is not controlled effectively.

End Connections

Thread (M)
Flange (F)
Victaulic (V)

- Each filter is designed and manufactured in order to achieve the highest standard of quality and finish.

HEAD LOSS/ FLOW RATE

Metric Units

Head Loss

Model	Flow Rate Q (m ³ /h)												
	5	10	15	20	25	30	35	40	45	50	55	60	70
	Head Loss dP (bar)												
4121 (1")	0.08	0.31	0.69	1.23									
41615 (1 1/2") 4162 (2")	0.04	0.16	0.36	0.64	1.00	1.44							
4202 (2")		0.10	0.22	0.39	0.61	0.88	1.20						
4203 (3")		0.06	0.13	0.24	0.37	0.54	0.73	0.95	1.20	1.49			
4242 (2")		0.04	0.09	0.15	0.24	0.35	0.47	0.62	0.78	0.96	1.16		
4243 (3")				0.09	0.14	0.19	0.26	0.35	0.44	0.54	0.65	0.78	1.06

Model	Flow Rate Q (m ³ /h)															
	20	30	40	50	60	70	80	90	100	110	130	150	180	200	220	250
	Head Loss dP (bar)															
4303 (3")	0.06	0.14	0.26	0.40	0.58	0.79	1.03									
4363 (3")		0.07	0.13	0.20	0.28	0.38	0.50	0.63	0.78	0.95						
4484 (4")				0.06	0.08	0.11	0.15	0.19	0.23	0.28	0.39	0.53	0.76	0.93	1.13	
4604 (4")					0.05	0.06	0.08	0.10	0.13	0.15	0.21	0.28	0.41	0.50	0.61	0.79
4303U (3")	0.06	0.14	0.26	0.40	0.58	0.79	1.03									
4363U (3")		0.07	0.13	0.20	0.28	0.38	0.50	0.63	0.78	0.95						
4484U (4")				0.06	0.08	0.11	0.15	0.19	0.23	0.28	0.39	0.53	0.76	0.93	1.13	
4604U (4")					0.05	0.06	0.08	0.10	0.13	0.15	0.21	0.28	0.41	0.50	0.61	0.79

Head Loss/Flow Rate

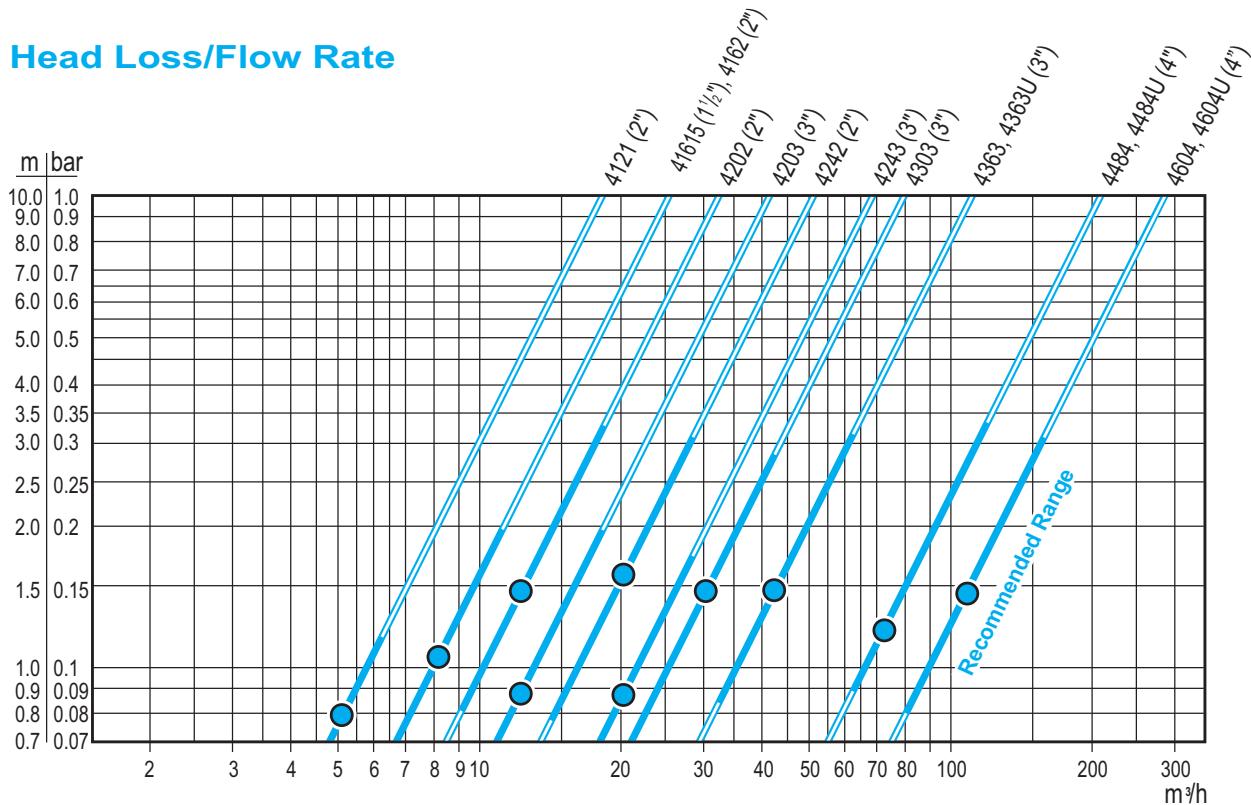

● Average Point - Head Loss / Flow Rate

■ 1 bar=100 kPa=1.02 kg/cm²=10.2 m (W.C)=14.5 psi

HEAD LOSS/ FLOW RATE

U.S. Units

Head Loss

Model	Flow Rate Q (U.S. gpm)														
	20	40	60	80	100	125	150	175	200	225	250	275	300	325	350
	Head Loss dP (psi)														
4121 (1")	0.9	3.7	8.3	14.8											
41615 (1½") 4162 (2")	0.5	1.9	4.3	7.7	12.0	18.7									
4202 (2")	0.3	1.2	2.6	4.7	7.3	11.4	16.4								
4203 (3")	0.2	0.7	1.6	2.8	4.4	6.9	10.0	13.6	17.8						
4242 (2")	0.1	0.5	1.0	1.8	2.9	4.5	6.5	8.8	11.5	14.6	18.0				
4243 (3")		0.3	0.6	1.0	1.6	2.5	3.6	4.9	6.5	8.2	10.1	12.2	14.6	17.1	19.8

Model	Flow Rate Q (U.S. gpm)															
	100	125	175	200	225	250	275	300	350	400	500	600	700	800	900	1000
	Head Loss dP (psi)															
4303 (3")	1.2	1.9	3.7	4.8	6.1	7.5	9.1	10.8	14.7							
4363 (3")	0.6	0.9	1.8	2.3	3.0	3.7	4.4	5.3	7.2	9.4	14.6					
4484 (4")			0.5	0.7	0.9	1.1	1.3	1.6	2.1	2.8	4.4	6.3	8.6	11.2	14.1	
4604 (4")					0.05	0.6	0.7	0.8	1.2	1.5	2.4	3.4	4.6	6.0	7.6	9.4
4303U (3")	1.2	1.9	3.7	4.8	6.1	7.5	9.1	10.8	14.7							
4363U (3")	0.6	0.9	1.8	2.3	3.0	3.7	4.4	5.3	7.2	9.4	14.6					
4484U (4")			0.5	0.7	0.9	1.1	1.3	1.6	2.1	2.8	4.4	6.3	8.6	11.2	14.1	
4604U (4")					0.05	0.6	0.7	0.8	1.2	1.5	2.4	3.4	4.6	6.0	7.6	9.4

Head Loss/Flow Rate

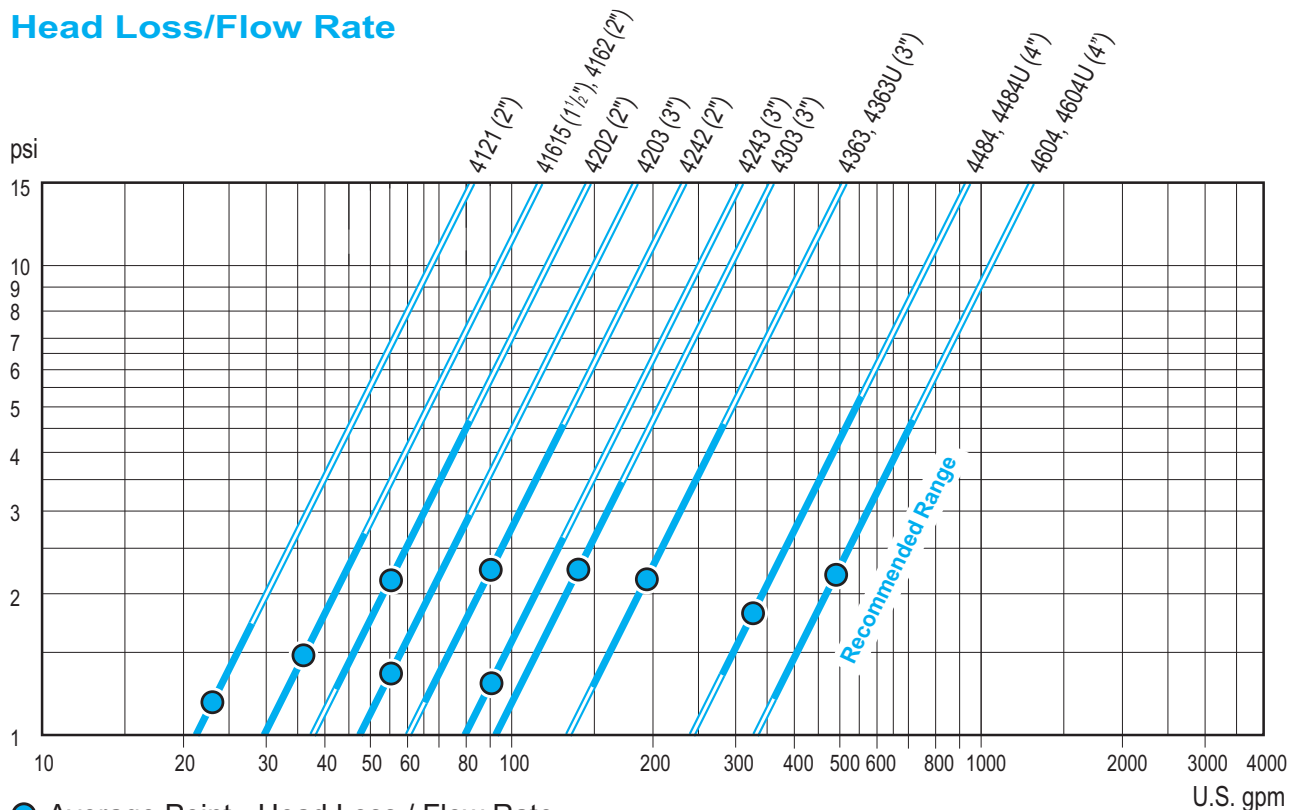

● Average Point - Head Loss / Flow Rate

■ 1 psi=0.069 bar=6.9 kPa=0.07 kg/cm²=0.7 m (W.C)

ILLUSTRATED PARTS BREAKDOWN

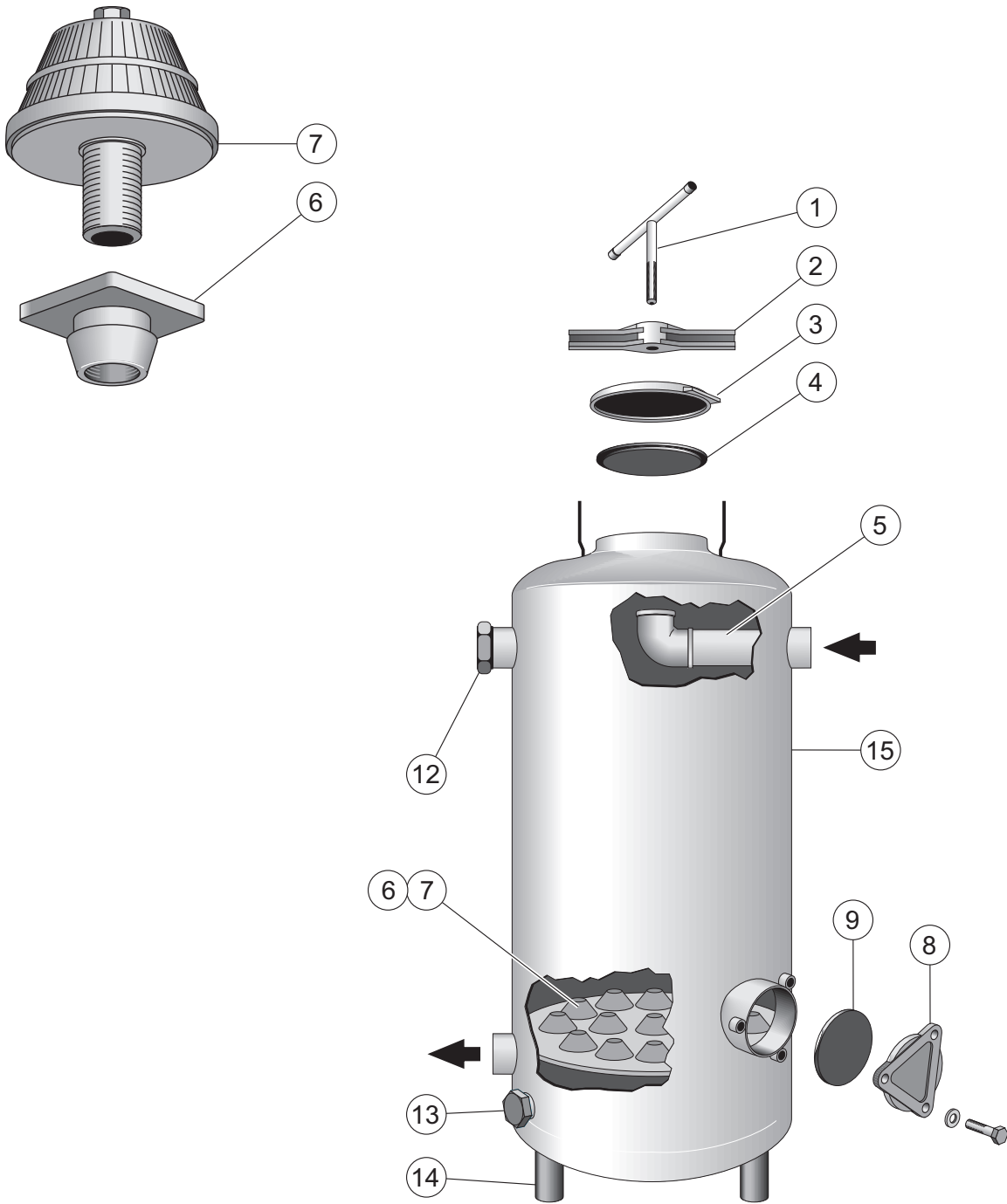

Catalog Numbers

Part No.	Description	Model					
		4121 (1")	4162 (2")*	4202 (2")	4203 (3")	4242 (2")	4243 (3")
1	Handle	E 000 100	E 000 100	E 000 100	E 000 100	E 000 100	E 000 100
2	Tightening Bracket	E 000 216	E 000 218	E 000 218	E 000 218	E 000 218	E 000 218
3	Cover	E 000 260	E 000 280	E 000 280	E 000 280	E 000 280	E 000 280
4	Cover Gasket	E 004 365	E 004 380	E 004 380	E 004 380	E 004 380	E 004 380
5	Conduit	E 405 700	E 400 700	E 410 700	E 420 700	E 424 700	E 424 701
6	Rubber Bushing	E 400 720	E 400 720	E 400 720	E 400 720	E 400 720	E 400 720
7	"Mushroom" Diffusers	E 400 400	E 400 400	E 400 400	E 400 400	E 400 400	E 400 400
8	Service Opening Cover	E 400 240	E 400 240	E 400 260	E 400 260	E 400 260	E 400 260
9	Service Opening Cover Gasket	E 001 340	E 001 340	E 004 365	E 004 365	E 004 365	E 004 365
12	Male Plug	H 070 310 (1")	H 070 320 (2")	H 070 320 (2")	H 070 320 (2")	H 070 320 (2")	H 070 320 (2")
13	Male Plug	----	H 070 310 (1")	H 070 310 (1")	H 070 310 (1")	H 070 315 (1 1/2 ")	H 070 315 (1 1/2 ")
14	Rubber Leg	E 004 367	E 004 367	E 004 367	E 004 367	E 004 368	E 004 368
15	Filter Body	A 4121	A 4162	A 4202	A 4203	A 4242	A 4243

* Available with 1 1/2" Inlet Outlet (Model 41615).

■ Aimed at continued improvement, ODIS reserves the right to change specifications without prior notice.

ILLUSTRATED PARTS BREAKDOWN

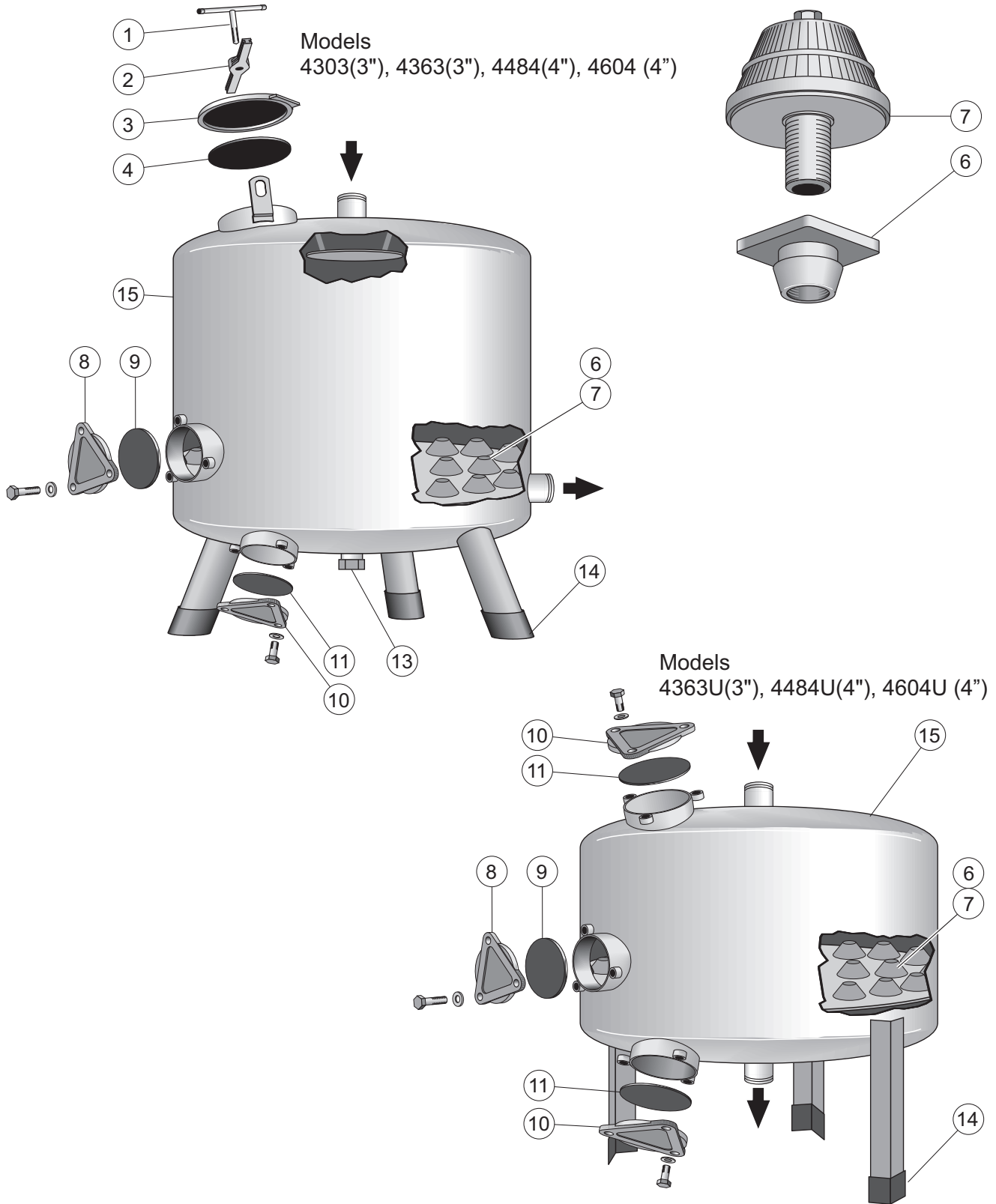

Catalog Numbers

Part No.	Description	Model						
		4303 (3")	4363 (3")	4484 (4")	4604 (4")	4363U (3")	4484U (4")	4604U (4")
1	Handle	E000100	E000100	E000100	E000100	-	-	-
2	Tightening Bracket	E000218	E000218	E000218	E000218	-	-	-
3	Cover	E001280	E001280	E001280	E001280	-	-	-
4	Cover Gasket	E004381	E004381	E004381	E004381	-	-	-
6	Rubber Bushing	E400720	E400720	E400720	E400720	E400720	E400720	E400720
7	"Mushroom" Diffusers	E400400	E400400	E400400	E400400	E400400	E400400	E400400
8	6" Service Cover	E400260	E400260	E400260	-	E400260	E400260	-
	8" Service Cover	-	-	-	E002280	-	-	E002280
9	6" Service Cover Gasket	E004365	E004365	E004365	-	E004365	E004365	-
	8" Service Cover Gasket	-	-	-	E004381	-	-	E004381
10	6" Service Cover	E400260	E400260	-	-	-	-	-
	8" Service Cover	-	-	E002280	E002280	E002280	E002280	E002280
11	6" Service Cover Gasket	E004365	E004365	-	-	-	-	-
	8" Service Cover Gasket	-	-	E004381	E004381	E004381	E004381	E004381
13	Male Plug	H070320	H070320	H070320	H070320	-	-	H070320
14	Rubber Leg	E004368	E004368	E004488	E004488	E004369	E004369	E004488
15	Filter Body	A4303	A4363	A4484	A4604	A4363U	A4484U	A4604U

- Aimed at continued improvement, ODIS reserves the right to change specifications without prior notice.

Recommended Media

Recommended media for typical conditions:

Media Type	Particle Size	Expected Filtration at 20 - 30 U.S. gpm/ft ² 50 - 75 m ³ /h/m ²
	mm	
Crushed Granite No. 11	1.2 - 1.8	70 - 100 microns
Crushed Basalt No. 1	1.2 - 1.8	70 - 100 microns
Crushed Silica No. 16	0.8 - 1.2	80 - 110 microns

NOTES:

- Media should be crushed with sharp edges, for efficient filtration.
- Flow recommendation according to dirt load:
 - 75 m³/h/m² (30 U.S. gpm/ft²) for average water.
 - 50 m³/h/m² (20 U.S. gpm/ft²) for dirty water.
- For special water condition, e.g. iron content and recycled water, other media types are available at lower flow rates - consult our service department.

Gravel Filling

Models	Inlet / Outlet Diameters	Gravel Filling	Gravel Filling
	inch	(kg)	(lbs)
4121	1"	60	130
4162, (41615)	2" (1½")	90	200
4202	2"	120	260
4203	3"	120	260
4242	2"	180	400
4243	3"	180	400
4303	3"	240	530
4363	3"	360	790
4484	4"	630	1400
4604	4"	990	2200
4363U	3"	300	660
4484U	4"	570	1260
4604U	4"	990	2200

GENERAL INSTRUCTIONS

For best results, the filter must be correctly installed and properly operated.

Special attention must be given to proper backflushing of the filter at the specified periodic intervals, chlorination at the beginning and at the end of the season and appropriate maintenance.

Automatic backflushing is optional even for a single filter.

Backflushing of an array of filters is performed without interfering with irrigation.

Operation

- Normal working conditions are obtained when headloss is less than 0.3 bar (5 psi) with clean filter.
- If headloss exceeds 0.3 bar (5 psi) - filter is either partially clogged or operating under an excessive flow rate.
- Backflush the filter at the beginning and at the end of irrigation. Chlorinate before end of irrigation, as necessary.
- Backflush filter when headloss increases by 0.3 - 0.5 bar (4.5 - 7.5 psi) above headloss of clean filter, or every 3 hours, whichever ever comes first.
- Verify headloss of filter by measuring pressure difference with installed pressure gauge and 3 way valve selector.
- Automatic backflushing by controller or computer is recommended.
- For recommended flow rates for filtering and backflushing see page 6.
- Maximal operational pressure should not exceed 8 bar (120 psi).
- Filter is designed to withstand a maximum pressure of 10 bar (150 psi).
- Do not tighten or open covers during operation or under pressure.

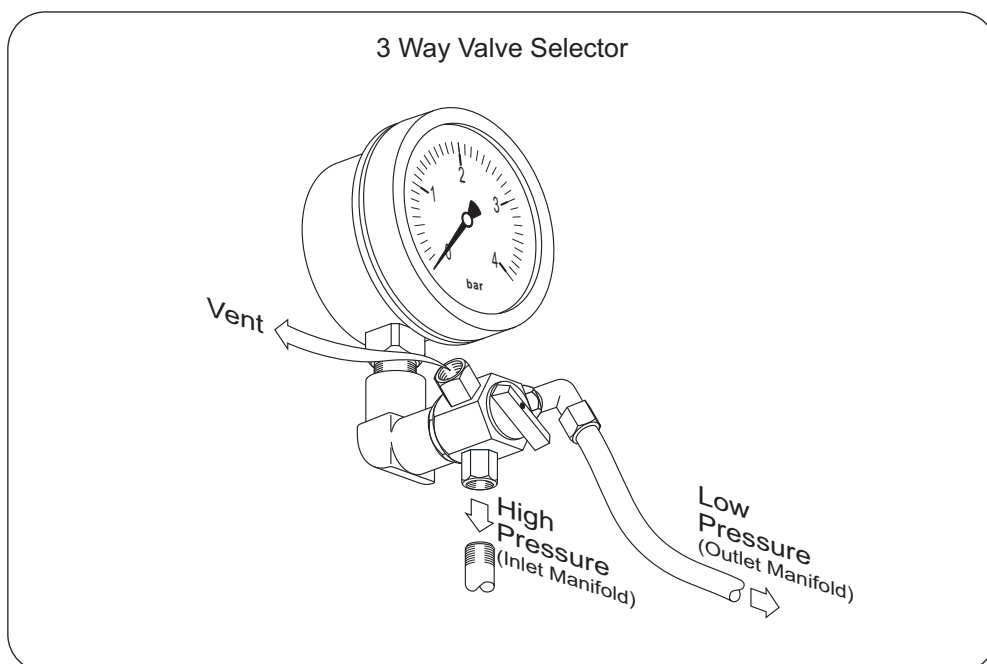

Backflushing of a Single Filter

- During normal filtering (irrigation), valves A and B are open, while valves C and D are closed. (valve C is a throttling valve).
- Backflushing of filter (manual):
 - a. The filter must be backflushed periodically according to water quality, water flow and field conditions.
 - b. Close valves A and B, then open valves C and D. Backflush for 45 to 90 second (see fig. 2). (For automatic backflushing, time is reduced, see arrays).
 - c. Return to normal filtering, (see fig. 1).

NOTE:

If a Flow Limiting Valve (FLV) is not installed, throttle valve C so that no gravel/sand is lost during backflushing and the flow is good (see installation) when valve is "open".

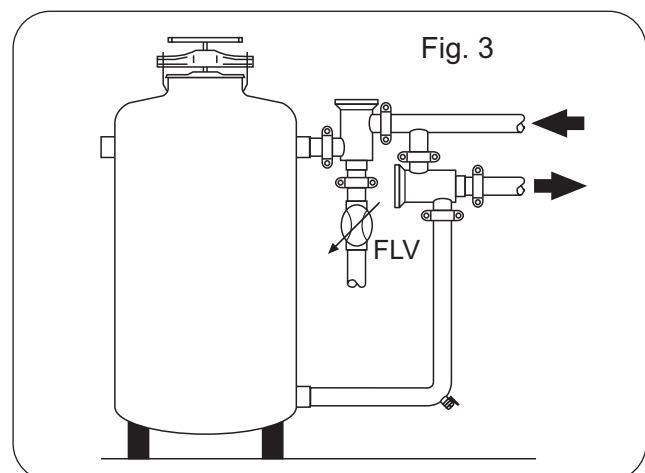
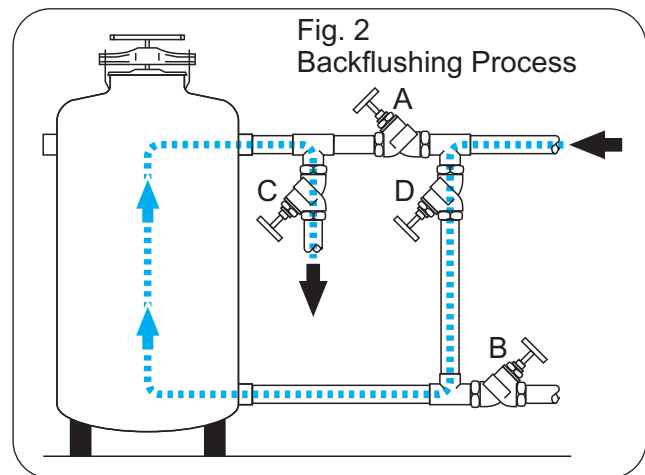
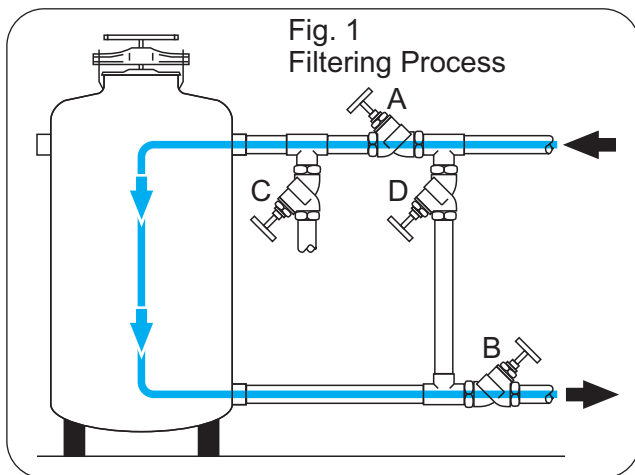

Integrated backflushing valves can replace valves A + C and valves B + D.

Backflushing of an Array of Filters

Backflushing of an array is performed one filter at a time using filtered water from the other filters, without necessarily interfering with irrigation.

- During normal filtering (irrigation), valve A is open and valve C is closed (see fig. 4).

NOTE:

If a flow limiting valve (FLV) is not installed, regulate the throttling valve F. Throttle the common valve F, so that no gravel/sand is lost during backflushing and the flow is good (see installation). Valve F remains partially open all the time. (A flow limiting valve is recommended).

- Automatic backflushing of filter

- The filter must be backflushed periodically according to water quality, water flow and field conditions.
- Valve A closes and valve C opens (see fig. 5). Backflush for a minimum of 30 seconds.
- When backflushing terminates, the filter array returns to normal; valve C closes and valve A opens (see fig. 4).

NOTE:

The steps described in b and c are performed automatically by an adequate controller (e.g. a time and differential pressure controller or computer control) backflushing one filter at a time or a number of filters.

Integrated backflushing valves can replace valves A + C.

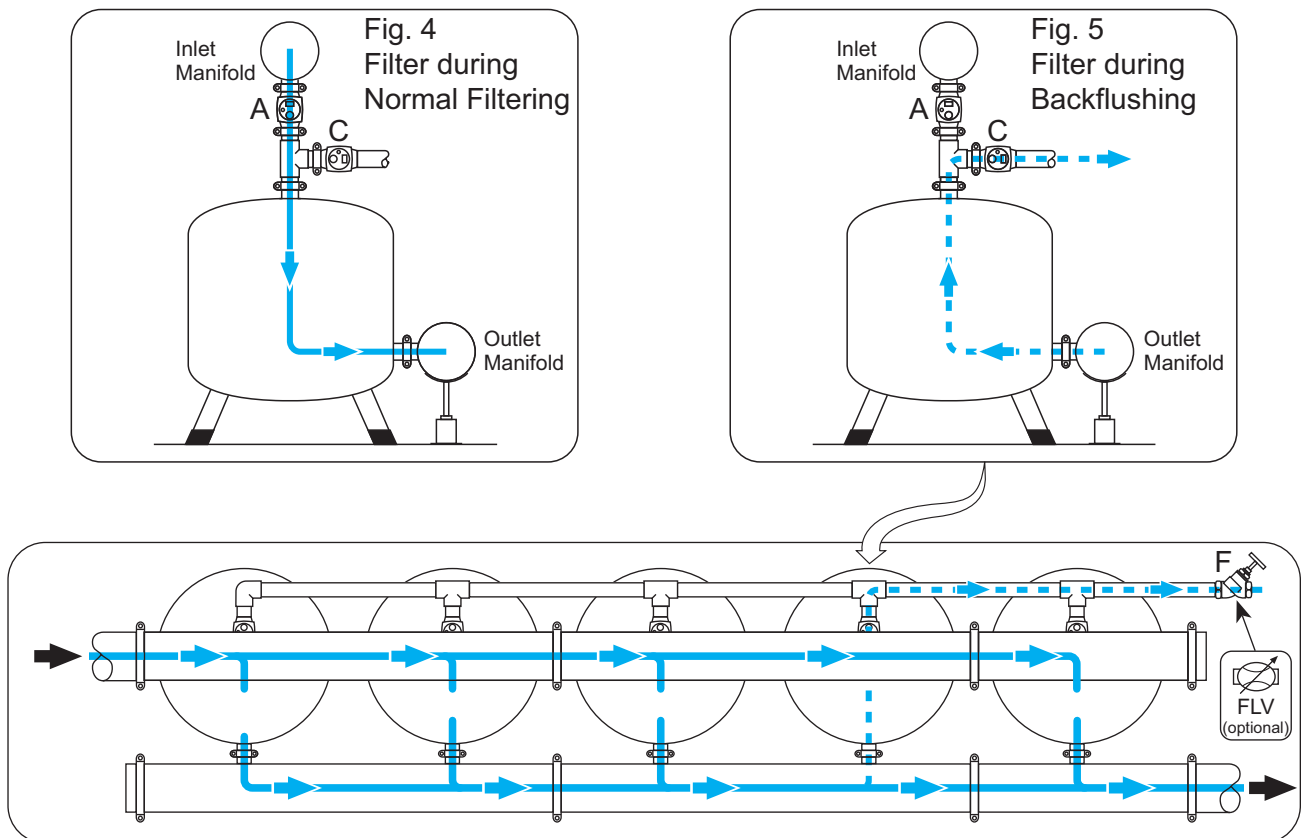

Installation

SINGLE FILTER

- Install the gravel filter in place.
- Assemble valves and connect to water system (see fig. 6).
- Special attention must be given to the correct flow direction.
- A pressure relief valve must be inserted before the filtering installation if pressure is not controlled effectively.

NOTE:

In automatic backflushing, install hydraulically operated valves with a response of less than 5 seconds to full opening or closing.

- Fill the filter through the top filling port with the proper quantity of media, see technical data page 14.
- Recommended media:
 - Crushed granite No.11.
 - Crushed basalt No.1.(minimum grain size of media: 0.6 mm).
- Close the top filling port with the cover.
- Mount tightening bracket (2) and tighten handle (1) properly.
- Verify that all service covers, valves and accessories are closed tightly. Check for leaks.
- Backflush the filter with the new media to wash out dirt, dust and fines, for at least two minutes.
- Before operation, backflush the filter to verify its proper functioning. This step is **of vital importance** for effective use of the filter:
 - a. Filter with FLV (Flow Limiting Valve *) - check all connections before backflushing. (See fig. 7).
 - b. Filter with throttling valve - open the valve (F) then close it gradually/slowly until no gravel/sand is lost in the outgoing water flow.
 - c. Filter with automatic control - check the controller is set as follows:
 - Backup Time - Set Time backup (between flushings) to a maximum of 3 hours (dirty water typically 1 - 2 hours)
 - Dwell Time - Set Dwell Time (duration of flushing) typical dwell time, for 2" valve: 40 - 60 seconds, (see installation).

* The flow limiting valve is an automatic flow regulator which closes when pressure increases, to keep the backflush flow rate constant.

Fig. 6
Integrated Valves

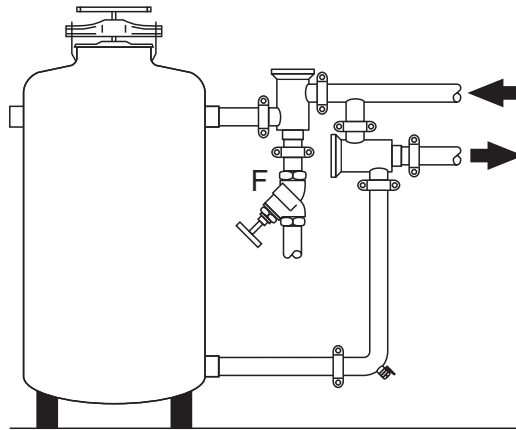
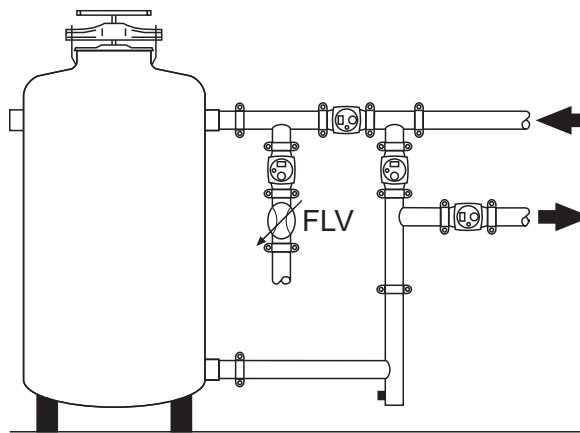

Fig. 7
Hydraulic Valves and FLV



ARRAY of FILTERS

- Install the gravel filters on their base (recommended on a concrete base) according to correct spacing, see drawing of the array.
- Do not make permanent connections and do not tighten bolts before installation is complete.
- Assemble valves on filter inlets.
- Assemble manifolds to filters, valves and main lines. Standard Odis manifolds are recommended for modular assembly of arrays.
- Special attention must be given to the correct flow direction.
- A pressure relief valve must be inserted before the filtering installation if pressure is not controlled effectively.

NOTE:

In automatic backflushing, install hydraulically operated valves with a response of less than 5 seconds to full opening or closing.

- Fill the filter through the top filling port with the proper quantity of media, see technical data, page 14.
- Recommended media:
 - Crushed granite No.11.
 - Crushed basalt No.1.
 - (minimum grain size of media: 0.6 mm).
- Close the top filling port with the cover.
- Mount tightening bracket (2) and tighten handle (1) properly.
- Verify that all service covers, valves and accessories are closed tightly. Check for leaks.
- Backflush the filter with the new media to wash out dirt, dust and fines, for at least two minutes.
- Before operation, backflush the filter to verify its proper functioning. This step is **of vital importance** for effective use of the filter:
 - a. Array with FLV (Flow Limiting Valve *) - check all connections before backflushing. (See fig. 8).
 - b. Array with throttling valve - open the valve (F) then close it gradually/slowly until no gravel/sand is lost in the outgoing water flow.
 - c. Array with automatic control (see fig. 9) - check that the controller is set as follows:
 - Backup Time - Set Time backup (between flushings) to a maximum of 3 hours (dirty water typically 1 - 2 hours)
 - Dwell Time - Set Dwell Time (duration of flushing) typical dwell times as follows:
 - 2" valve: 40 - 60 seconds.
 - 3" valve: 50 - 70 seconds.
 - 4" valve: 60 - 90 seconds.
- Activate the backflushing sequence in the controller and verify that filters are backflushed one after the other and that dwell time is correct. (Remember to install fresh batteries).

- * The flow limiting valve is an automatic flow regulator which closes when pressure increases, to keep the backflush flow rate constant.

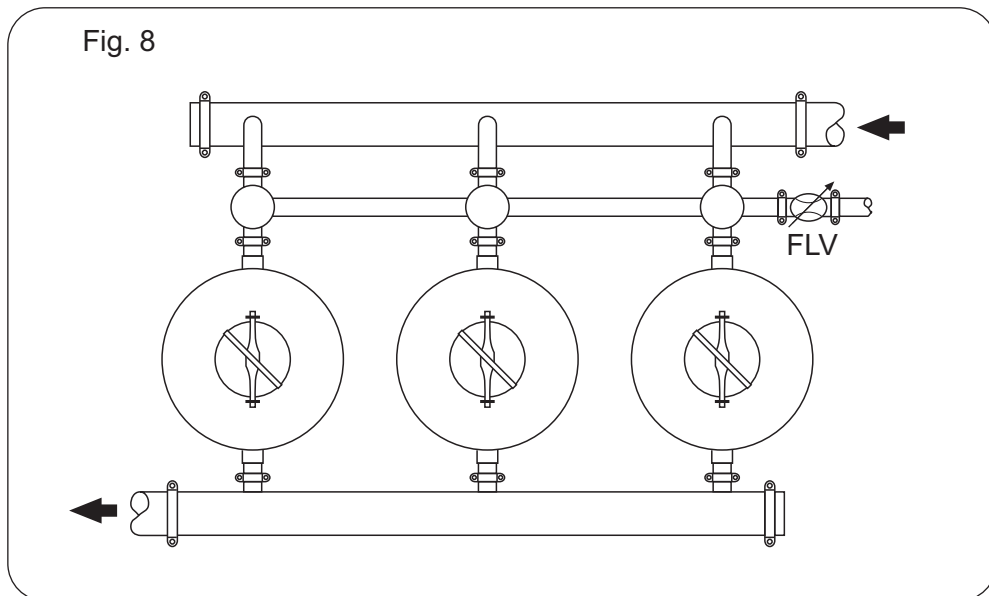
**NOTES:**

If the line pressure is low (and backflush flow rate is too low) a pressure sustaining valve on the outlet of the array may solve the problem. It is very important that this sustaining valve is active only during backflushing (otherwise it will interfere with the irrigation).

Do not damage the protective coating during installation. If coating is damaged by sharp tools, repair promptly. (see maintenance).

Periodic Cleaning

- Close valve at inlet and outlet of the filters.
- Release pressure within filter. Open the top filling port.
- Inspect media level and its cleanliness.
- If media is not effective (long service, stubborn caking or abraded media), replace - see Replacing Filter Media.

WARNING:

- **Do not tighten or open cover during operation or under pressure.**

NOTES:

Check flow limiting valve or throttling valve.
Replace batteries with fresh ones.

- At the beginning of the irrigation season, chlorinate the filter and backflush as follows:
Drain about half of the water and add liquid sodium hypochlorite (NaOCl) according to the chart, then fill the filter with water. The concentration will be the required one, 80 - 100 ppm.

Type of Hypochlorite	Quantity			
	Household Bleach (3%)		Commercial (10%)	
Models	Liters	Fluid Oz	Liters	Fluid Oz
4121	0.210	7	0.060	2.0
4162, (41615)	0.370	12	0.110	3.7
4202	0.550	18	0.170	5.7
4203	0.650	22	0.200	6.8
4242	0.830	28	0.250	8.5
4243	0.830	28	0.250	8.5
4303	1.150	39	0.320	10.8
4363	1.600	54	0.480	16.2
4484	3.000	101	0.900	30.4
4363U	1.450	49	0.430	14.5
4484U	2.650	90	0.800	27.1
4604/4604U	4.700	159	1.410	48.0

- 1 U.S. Gallon = 3.7854 liters.
- 1 U.S. Gallon = 4 quarts = 8 pints = 128 fluid ounces (Oz).
- 1 U.S. Pint = 16 fluid ounces.

Wait for 30 minutes (no water flowing) then backflush the filter.

- At the end of the irrigation season, chlorinate as above (beginning of the irrigation season), during an irrigation interval approx. 1 hour before irrigation ends.
- Backflush the filter 2 – 3 times, 2 minutes every time. Then complete the irrigation as planned. This will get rid of chlorine residues.
- Drain all the water from the filter, leaving it dry.
- Close both inlet and outlet valves.

Replacing Filter Media

Replace the gravel when the amount of dirt (that cannot be backflushed), prevents proper functioning of the filter.

- Close all the valves.
- Open the top filling port.
- Open the side service port gently and drain all the water.
- Empty the gravel from the filter, through the side service port.
- Rinse the interior of the filter thoroughly with clean water.
- Inspect the double bottom of the filter and the "mushroom" diffusers.
- Check the protective coating for damage and repair (if necessary).
- Cover the side service ports and tighten properly.
- Fill the filter through the top filling port (see installation).
- Check the flow limiting valve, or readjust the throttle valve (F) (see installation).
- Open valves for normal operation (see operation).

Maintenance

- Each filter is supplied with maintenance instructions, as well as assembly, installation and operation instructions.
- Apply a layer of grease to thread of handle (1) once a year.
- Any damage to the protective coating of filter must be repaired without delay. Prior to the application of the protective paint, thoroughly clean the damaged spot with a wire brush.

How To Order Odis Gravel / Sand Filters

1. Type of filter required.
2. Catalog Number of filter.
3. End connections: Thread (M)
Flange (F)
Victaulic (V)
4. Min./max. pressure.
5. Maximal/Minimal Flow rate.
6. Media type (see page 14).
7. Additional accessories: Nipples/Valves/Flushing-Valves/Pilots/relays/Manifolds/Pressure Gauges.
8. Filter arrays: see chapter 1.(*)
9. Other than standard material, required for filter body: Stainless Steel.
10. Special Coating Requirements.

*** An array of gravel filters is a complete solution for various flow rates and water quality based on standard products.
This enhances flexibility and facilitates any future enlargement or changes of the array.**

Filter Catalog Numbers

Model	Thread (M)	Flange (F)	Victaulic (V)
4121 (1")	4121 M - Female		
41615 (1½")	41615 M - Female		41615 V *
4162 (2")	4162 M - Female		4162 V *
4202 (2")	4202 M - Female		4202 V *
4203 (3")	4203 M - Female		4203 V *
4242 (2")	4242 M - Female		4242 V *
4243 (3")	4243 M - Female		4243 V *
4303 (3")	4303 M - Female	4303 F	4303 V
4363 (3")		4363 F	4363 V
4484 (4")		4484 F	4484 V
4604 (4")		4604 F	4604 V
4363U (3")		4363U F	4363U V
4484U (4")		4484U F	4484U V
4604U (4")		4604U F	4604U V

* With Thread/Victaulic Adaptor

PACKING / SHIPPING DATA
Metric Units

Model	Inlet/Outlet Diameter (inch)	Body Diameter (inch)	Weight (kg)	Length (m)	Width (m)	Height (m)	Gross Volume (m ³)
4121	1"	12"	42	0.35	0.35	1.15	0.14
4162 *	2"	16"	50	0.45	0.45	1.05	0.19
4202	2"	20"	70	0.5	0.5	1.25	0.31
4203	3"	20"	75	0.55	0.55	1.4	0.42
4242	2"	24"	90	0.65	0.65	1.35	0.6
4243	3"	24"	90	0.65	0.65	1.35	0.6
4303	3"	30"	136	0.8	0.8	1.1	0.7
4363	3"	36"	185	1.0	1.0	1.1	1.15
4484	4"	48"	310	1.3	1.3	1.1	1.9
4604	4"	60"	430	1.6	1.6	1.4	2.4
4363U	3"	36"	200	1.0	1.0	1.3	1.3
4484U	4"	48"	330	1.3	1.3	1.4	2.4
4604U	4"	60"	460	1.6	1.6	1.9	4.9

* Available with 1½" Inlet Outlet (Model 41615).

U.S. Units

Model	Inlet/Outlet Diameter (inch)	Body Diameter (inch)	Weight (lbs)	Length (inch)	Width (inch)	Height (inch)	Gross Volume (cu.ft)
4121	1"	12"	90	14	14	45	5
4162*	2"	16"	110	18	18	41	6.8
4202	2"	20"	155	20	20	49	11
4203	3"	20"	198	22	22	55	14.9
4242	2"	24"	200	26	26	53	21.3
4243	3"	24"	200	26	26	53	21.3
4303	3"	30"	300	32	32	43	24.8
4363	3"	36"	400	39	39	43	40.8
4484	4"	48"	680	51	51	43	67.3
4604	4"	60"	950	63	63	55	84.8
4363U	3"	36"	726	39	39	52	46
4484U	4"	48"	730	51	51	56	85
4604U	4"	60"	1015	63	63	75	173

* Available with 1½" Inlet Outlet (Model 41615).