



## Multi-Jet Magnetic Water Meter Model M

Water meters using the multi-jet principle are the best cost/performance, long life, flow measurement instruments. Wide clearances in the measuring chamber and negligible area of contact between static and moving parts are the main reasons for the high reliability of this design even in hard water.



MH-M type meter for **HOT** water

### Features:

- Only one moving part - the impeller - in contact with the water for minimum wear and utmost reliability.
- Magnetically driven sealed registers. Stainless steel/glass encapsulated option is unconditionally guaranteed against fogging.
- Wide selection of dial configurations (3 pointers; central pointer), units of measurements and different options of electrical output.
- All ARAD electrical output versions are adaptable to the meter.

### Applications

For domestic, agriculture and industrial use.

### Available Sizes

1/2" - 2" (15mm - 50mm).

### Standards

ISO 4064, AWWA, C 708, SI 63

### Technical Specifications

<b>Maximum Working Pressure</b>	10 bar
<b>Maximum Working Temperature</b>	50°C 90°C – For <b>HOT</b> water
<b>Body</b>	Corrosion proof copper alloy
<b>Coupling threads</b>	BSP, NPT

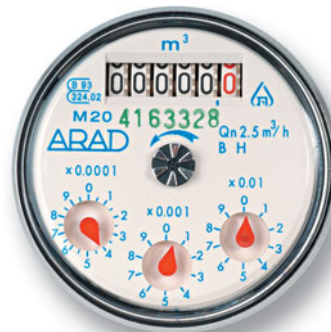

M type dial



► Velocity Type Meters

- └ Multi Jet - M
- └ Single Jet

Volumetric Meters

### Performance data:

Model	Nominal Size (inch)	Qmax Maximum flowrate (m <sup>3</sup> /h)	Qn Nominal flowrate (m <sup>3</sup> /h)	Qt Transitional Flowrate (l/h)	Qmin Minimum Flowrate (l/h)	Maximum register capacity (m <sup>3</sup> )	Minimum register capacity (liter)	Accuracy between Qmax & Qt	Accuracy between Qt & Qmin
M15	1/2"	3	1.5	120	30	10 <sup>5</sup>	0.1	±2%	±5%
M20	3/4"	5	2.5	200	50	10 <sup>5</sup>	0.1		
M25/7	1"	7	3.5	280	70	10 <sup>5</sup>	0.1		
M25/10	1"	10	5	400	100	10 <sup>5</sup>	0.1		
M30	1 1/4"	12	6	480	120	10 <sup>5</sup>	0.1		
M40	1 1/2"	20	10	800	200	10 <sup>6</sup>	1		
M50	2"	30	15	3000	450	10 <sup>6</sup>	1		

### Dimensions

Model		M15 (short)	M15	M20	M25	M40	M40	M50
Nominal size	(mm)	15	15	20	25	30	40	50
	(inch)	1/2	1/2	3/4	1	1 1/4	1 1/2	2
L – Length without couplings (mm)		165	190	190	260	260	300	300
L1 – Length with couplings (mm)		260	285	285	375	375	435	460
B – Width (mm)		95	95	95	105	105	125	160
H – Height (mm)		108	108	108	108	108	170	190
Weight (kg)		1.9	2	2	2.8	2.8	6.8	10.3
Weight with couplings (kg)		2.1	2.2	2.3	3.3	3.45	7.8	11.7

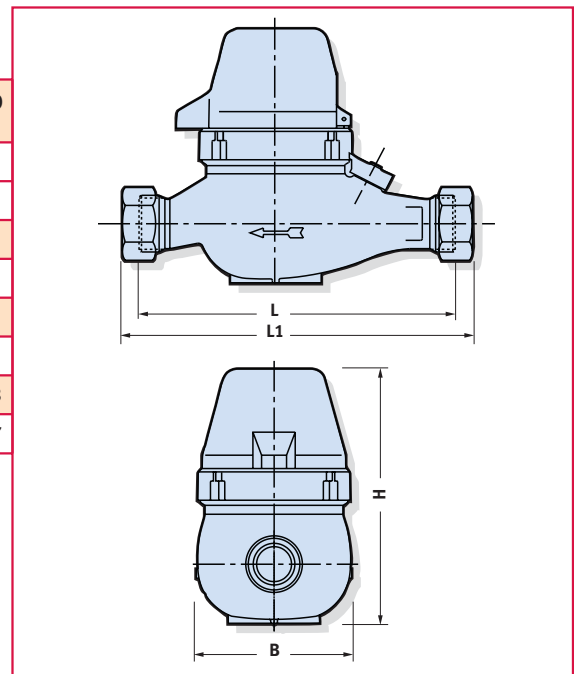

### Accuracy Curve

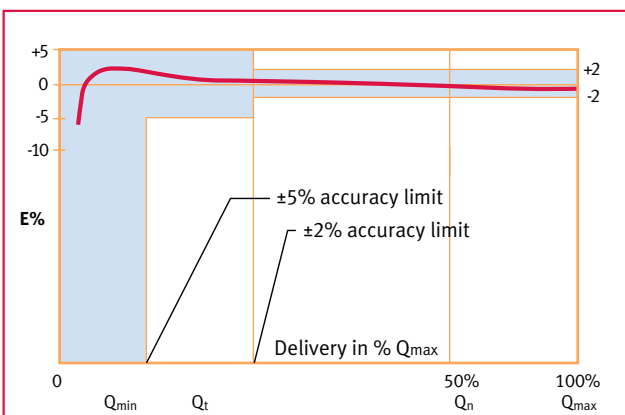

### Head Loss Curve

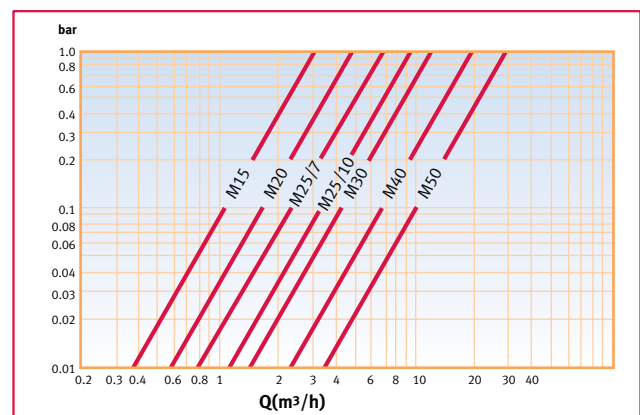

### Installation Requirements

- The Meter should be installed in horizontal position.
- Pipeline must be flushed before installation.
- The meter should be constantly full of water.

