

Valve Boxes

COMMERCIAL I320 Full Height and Half Height

Key Properties

	Body & Lid Material	Weight	Overall Height	Body & Lid Colour	Optional Purple Lid
Full Height	HDPE	5.3 kg	360mm	Green	Yes
Half Height	HDPE	3.5 kg	152mm	Green	Yes

Features & Benefits

- Moulded from HDPE to provide rigidity and resist warping
- No pipe cut-outs to allow complete flexibility with professional installations. It avoids the need to cover the cut-out when not required and prevent dirt ingress
- T-lid to prevent dirt from accumulating around the edges and to provide added strength
- Lid states "Irrigation Control Valve" to allow easy identification as to what is in the box
- Lock down bolt (plated) is standard to allow the lid to be secured and provide vandal resistance (nut is standard part of the moulding process)
- Optional Stainless Steel bolt available to allow the lid to be secured and provide vandal resistance
- Optional purple lids available are for recycled water applications
- I320 full height boxes can be nested for ease of storage



VBC I32012 - Full Height



VBC I32006 - Half Height

Valve Boxes

COMMERCIAL I320 - Full Height and Half Height

VBCI32012 - Full Height

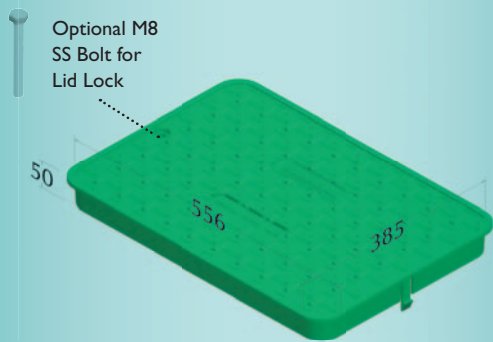

Nut is built-in to suit Bolt.

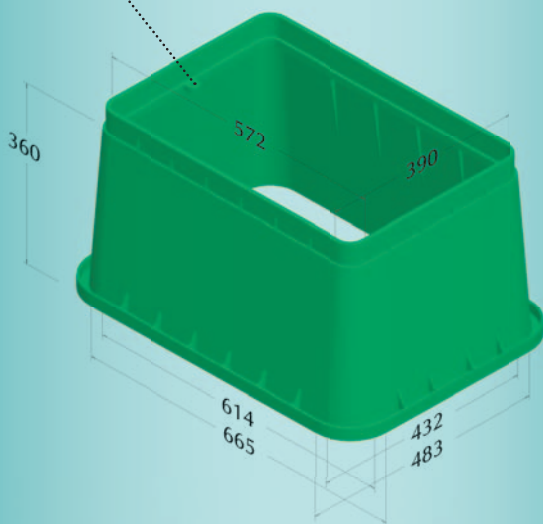

PLEASE NOTE: All dimensions are in mm and are approximate.

VBCI32006 - Half Height

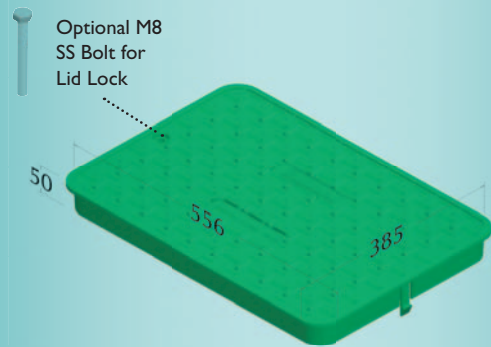

Nut is built-in to suit Bolt.

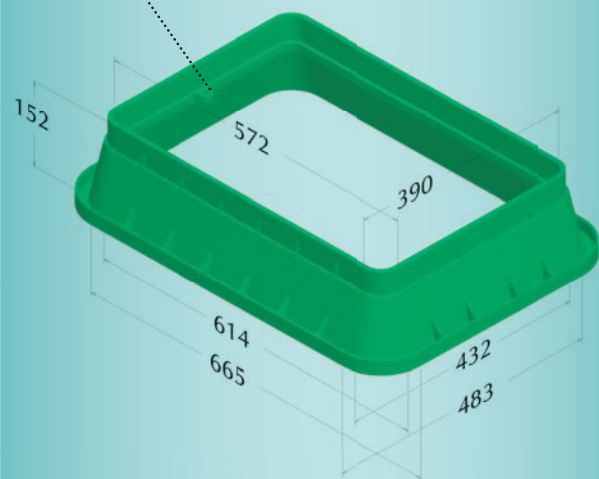

PLEASE NOTE: All dimensions are in mm and are approximate.