

# Valve Boxes

## COMMERCIAL 1419 Full Height and Half Height

### Key Properties

	Body & Lid Material	Weight	Overall Height	Body & Lid Colour	Optional Purple Lid
Full Height	HDPE	3.9 kg	314 mm	Green	Yes
Half Height	HDPE	2.3 kg	155 mm	Green	Yes

### Features & Benefits

- Moulded from HDPE to provide rigidity and resist warping
- Snap-lock tabs on the lid to prevent it from being accidentally knocked off
- T-lid to prevent dirt from accumulating around the edges and to provide added strength
- Lid states "Irrigation Control Valve" to allow easy identification as to what is in the box
- Optional Stainless Steel bolt available to allow the lid to be secured and provide vandal resistance (nut is standard part of the moulding process)
- Optional purple lids available when recycled water is being used
- All boxes can be nested for ease of storage



VBC141912 - Full Height



VBC141906 - Half Height

# Valve Boxes

## COMMERCIAL 1419 - Full Height and Half Height

### VBC141912 - Full Height

Identification "Irrigation Control Valve" or "Non Potable Water" on Purple Lids

Optional M8 SS Bolt for Cover Lock

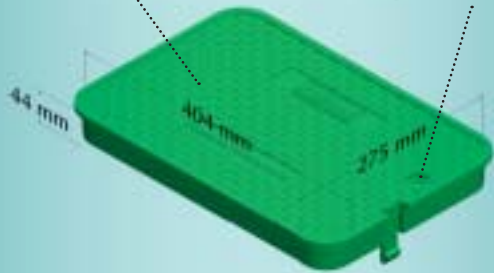

Nut is built-in to suit optional SS Bolt.

Snap Lock Tab

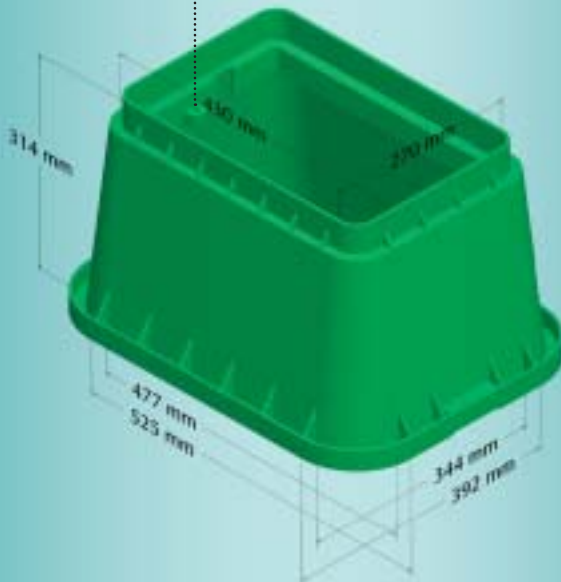

PLEASE NOTE: All dimensions are approximate.

### VBC141906 - Half Height

Identification "Irrigation Control Valve" or "Non Potable Water" on Purple Lids

Optional M8 SS Bolt for Cover Lock

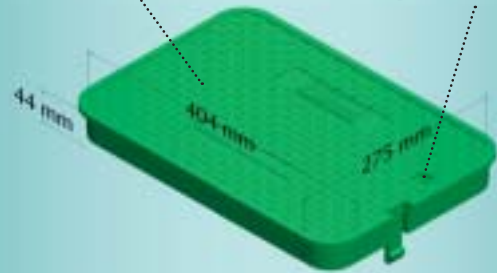

Nut is built-in to suit optional SS Bolt.

Snap Lock Tab

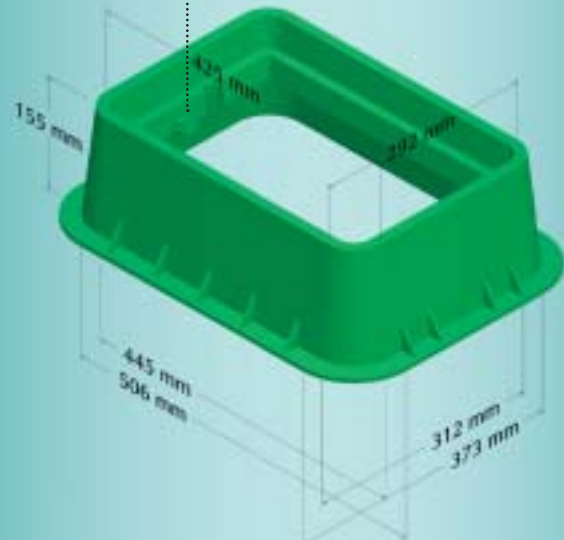

PLEASE NOTE: All dimensions are approximate.