

Series 25AUB-Z3

Water Pressure Reducing Valves*

Sizes: 1/2" – 2" (15 – 50mm)

Series 25AUB-Z3 Water Pressure Reducing Valves are designed to reduce incoming water pressure to a sensible level to protect plumbing system components and reduce water consumption. This series is suitable for water supply pressures up to 300psi (21 bar) and may be adjusted from 25 – 75psi (172 – 517kPa). The standard setting is 50psi (345kPa). All parts are quickly and easily serviceable without removing the valve from the line. The standard bypass feature permits the flow of water back through the valve into the main when pressures, due to thermal expansion on the outlet side of the valve, exceed the pressure in the main.

Features

- Standard construction includes Z3 sealed spring cage and corrosion resistant adjusting & cage screws for outdoor/waterworks pit installations
- Union inlet connection
- Integral stainless steel strainer
- Replaceable seat module
- Bronze body construction
- Serviceable in line
- Bypass feature controls thermal expansion pressure**
- High temperature resistant reinforced diaphragm for hot water

Models

25AUB-Z3	NPT threaded female union inlet x NPT female outlet
25AUB-S-Z3	Solder union inlet x NPT female outlet
25AUB-DU-Z3	Double Union – NPT threaded union female inlet and outlet
25AUB-S-DU-Z3	Double Union – Solder union inlet and outlet
25AUB-DU-THDxPEX-Z3	Double Union – NPT threaded female inlet and PEX union outlet
25AUB-DU-CPVC-Z3	Double Union – CPVC union inlet and outlet
25AUB-DU-LF-Z3	Double union body less fittings

Specifications

Standard Specifications: A Water Pressure Reducing Valve with integral strainer shall be installed in the water service pipe near its entrance to the building where supply main pressure exceeds 60psi (413 kPa) to reduce it to 50psi (345 kPa) or lower. The valve shall feature a bronze body suitable for water supply pressures up to 300psi (21 bar). Provision shall be made to permit the bypass flow of water around the valve back into the main when pressures, due to thermal expansion on the outlet side of the valve, exceed the pressure in the main. Water Pressure Reducing Valve with built-in bypass check valves will be acceptable. Approved valve shall be listed to ASSE 1003 and IAPMO and certified to CSA B356. Valve shall be a Watts Regulator Company Series 25AUB-Z3.*

A water saving test program concluded that reducing the supply pressure from 80-50psi (551-346kPa) resulted in a water savings of 30%.

** Bypass will not work if inlet pressure is above 150psi (10.34 bar).

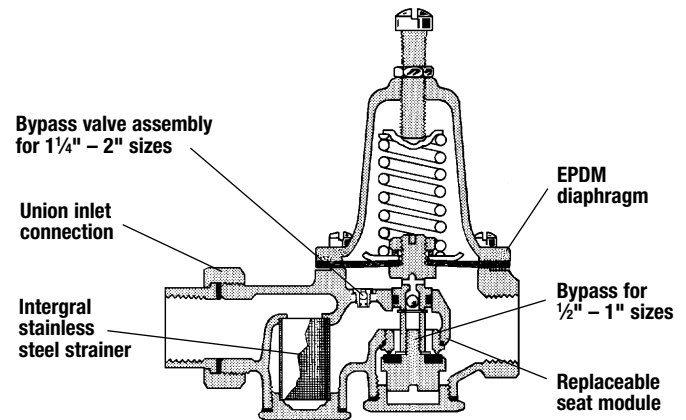
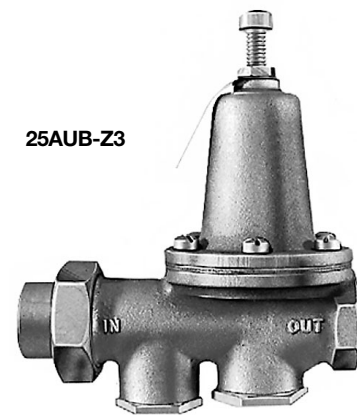

Lead Free Specifications: A Water Pressure Reducing Valve with integral strainer shall be installed in the water service pipe near its entrance to the building where supply main pressure exceeds 60psi (413 kPa) to reduce it to 50psi (345 kPa) or lower. The valve shall feature a bronze body where suitable for water supply pressures up to 300psi (21 bar). The combined metal components of the valve contacted by potable water shall contain less than one half of one percent (0.5%) lead by weight. Provision shall be made to permit the bypass flow of water around the valve back into the main when pressures, due to thermal expansion on the outlet side of the valve, exceed the pressure in the main. Water Pressure Reducing Valve with built-in bypass check valves will be acceptable. Approved valve shall be listed to ASSE 1003 and IAPMO and certified to CSA B356. Valve shall be a Watts Regulator Company Series LF 25AUB-Z3.

WATTS[®]
REGULATOR

Watts product specifications in U.S. customary units and metric are approximate and are provided for reference only. For precise measurements, please contact Watts Technical Service. Watts reserves the right to change or modify product design, construction, specifications, or materials without prior notice and without incurring any obligation to make such changes and modifications on Watts products previously or subsequently sold.

Materials

Body: Bronze
 Seat: 1/2"-1" (15-25mm) Replaceable engineered polymer
 (10% glass filled Noryl®)
 1 1/4"-2" (32-50mm) Replaceable stainless steel
 Integral Strainer: Stainless steel
 Diaphragm: Reinforced EPDM
 Valve Disc: EPDM

Note: for LP models where application temperatures exceed 160°F (71°C), but not over 180°F (82°C), a Teflon® protector should be added to sizes 1 1/4"-2" (32-50mm).

Pressure – Temperature

Temperature Range: 33°F - 160°F (5°C - 71°C)
 Maximum Working Pressure: 300psi (21 bars)
 Adjustable Reduced Pressure Range: 25-75psi (172 - 517kPa)
 Standard Reduced Pressure Setting: 50psi (345kPa)

Options

Add Suffix

G Gauge tapping, 1/8"
 GG Gauge tapping and 160psi (11 bar) gauge
 HP High pressure range 75-125psi (5.27 – 8.79 bar)
 LP Low pressure range 10-35psi (69 – 241 kPa)
 Z7 400psi (28 bar) initial pressure, 1/2" (20mm) models only

Add Prefix

LF Lead Free+ construction

†The combined metal components of this product contacted by potable water contain less than one half of one percent (0.5%) of lead by weight.

Noryl® is a registered trademark of General Electric Company.

Teflon® is a registered trademark of E.I. Dupont de Nemours & Company.

Dimensions – Weights

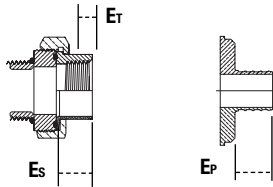

A - 25AUB-Z3
 A1 - 25AUB-S-Z3
 A2 - 25AUB-DU-LF-Z3
 B - 25AUB-DU-Z3
 B1 - 25AUB-S-DU-Z3
 B2 - 25AUB-DU-THDxPEX-Z3
 Et - NPT Engagement for tight joint
 Es - Female sweat socket depth
 Ep - PEX end connection



Meets requirements of ASSE Standard 1003: (ANSI A112.26.2: CSA Standard B356; Southern Standard Plumbing Code and listed by IAPMO. Military Standard MIL-V-18146B Type I.

Capacity

Sizes: 1/2", 3/4", 1", 1 1/4", 1 1/2", 2"
 (15, 20, 25, 32, 40, 50mm)

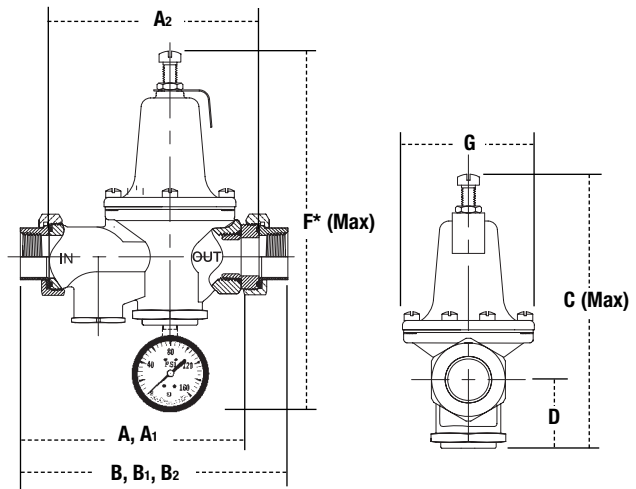
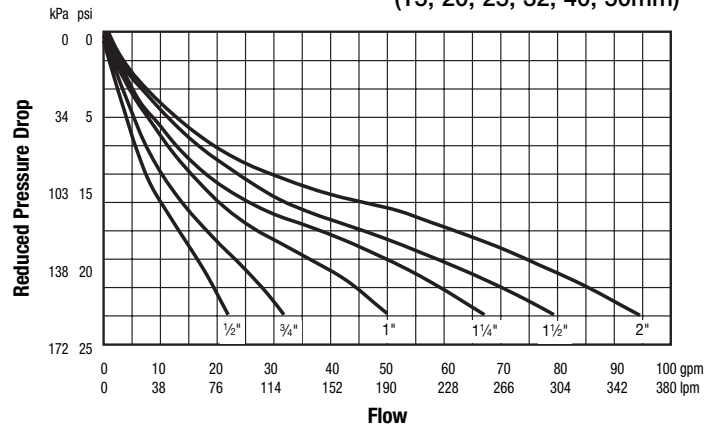

SIZE (DN)		DIMENSIONS											
in	mm	A		A1		A2		B		B1		B2	
		in	mm	in	mm	in	mm	in	mm	in	mm	in	mm
1/2	15	5 3/8	137	5 5/16	135	5 3/16	132	6 1/16	164	6 3/8	162	-	-
3/4	20	5 5/16	135	5 1/2	140	5 1/4	133	6 1/2	165	6 7/8	175	6 3/4	171
1	25	6	152	6 1/4	159	5 7/8	149	7 3/8	187	7 13/16	198	7 11/16	195
1 1/4	32	8 3/4	222	8 15/16	227	8 1/4	210	10 3/4	273	11	279	-	-
1 1/2	40	8 3/4	222	9	229	8 1/4	210	10 3/4	273	11 3/16	284	-	-
2	50	9 3/4	235	10	254	8 3/4	222	11 5/16	287	12 11/16	322	-	-

DIMENSIONS										WEIGHT					
C		D		F*		G		Et		Es		Ep		lbs.	kg.
in.	mm	in	mm	in	mm	in	mm	in	mm	in	mm	in	mm		
7	178	1 1/2	38	9 7/16	240	3 1/8	79	1/2	13	1/2	13	-	-	3.5	1.6
7	178	1 1/2	38	9 7/16	240	3 1/8	79	1/2	13	3/4	19	5/8	16	3.5	1.6
8	203	1 3/4	44	10 7/16	266	3 5/8	92	5/8	16	15/16	23	13/16	21	6.5	3.0
9	229	2 1/8	54	11 7/16	291	3 3/8	92	5/8	16	1	25	-	-	10	4.5
9 1/2	241	2 3/8	60	11 15/16	304	4 1/16	103	5/8	16	1 1/16	28	-	-	10	4.5
11 1/4	286	3 1/4	83	13 11/16	348	4 3/4	121	5/8	16	1 5/16	34	-	-	15	6.8

* Dimension includes optional gauge



USA: 815 Chestnut St., No. Andover, MA 01845-6098; www.wattsreg.com
 Canada: 5435 North Service Rd., Burlington, ONT. L7L 5H7; www.wattscanada.ca