

# TRAILCO®

## TRAVELLER T250-2

MODEL G

### SPARE PARTS



#### Trailco Irrigation (Aust.)

ABN: 35 480 117 190

1289 KINGSFORD SMITH DRIVE  
PINKENBA, QLD. 4008

P.O. BOX 1278, EAGLE FARM  
QLD. 4009, AUSTRALIA

PHONE: (07) 3260 1828 FAX: (07) 3260 1877

International Callers: Country (61) Area (7)

Web Site:- [www.trailco.com.au](http://www.trailco.com.au)

E-Mail:- [sales@trailco.com.au](mailto:sales@trailco.com.au)



# LOCATION OF MODEL/SERIAL No. PLATE

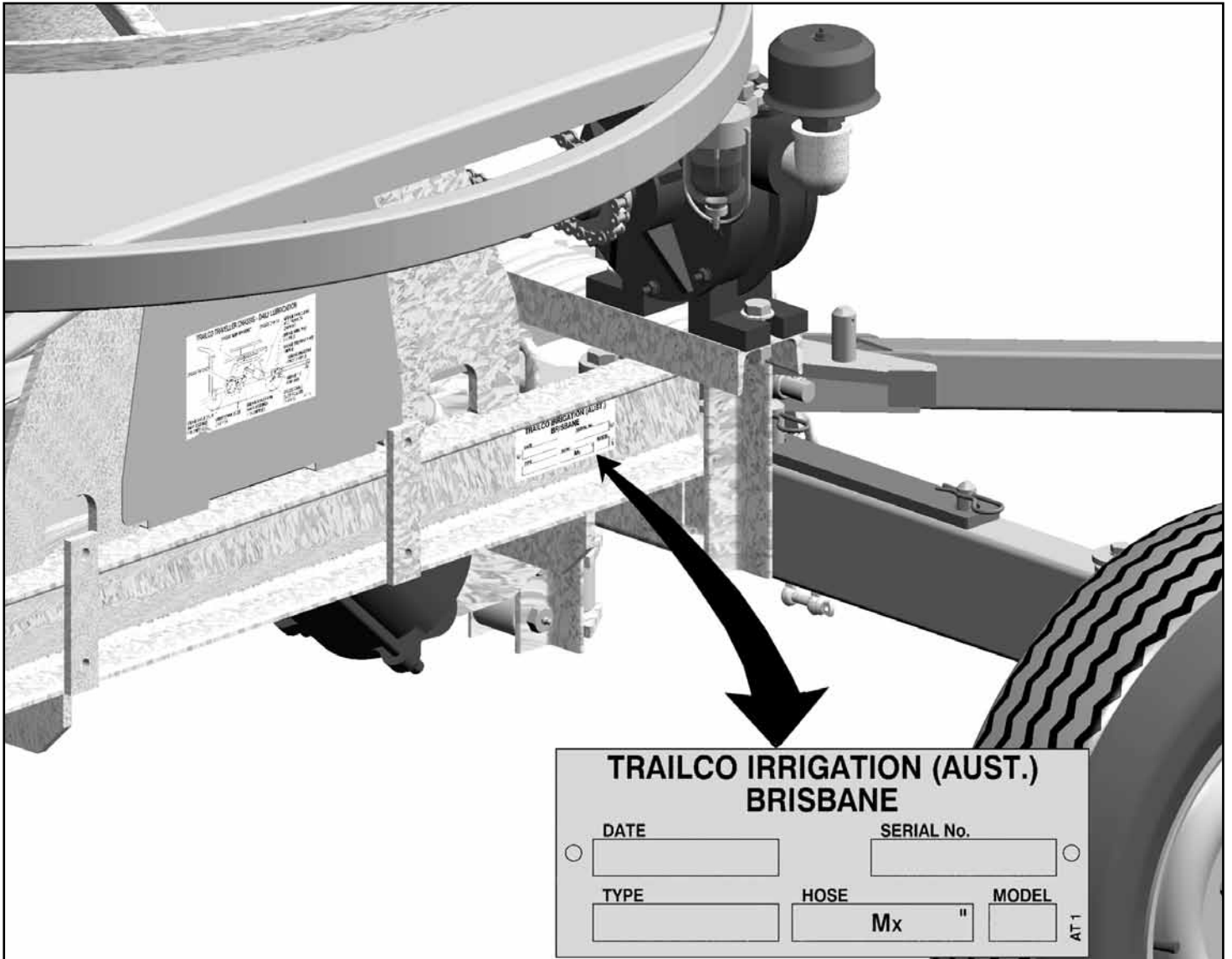

Please quote these details when ordering Spare Parts.

# TRAILCO TRAVELLER T 250-2

MODEL : G

SERIAL No. : 9201 ONWARDS

PART No. : 9205

DATE : 2NOV2005

## CONTENTS

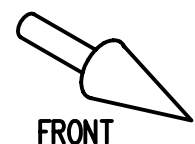
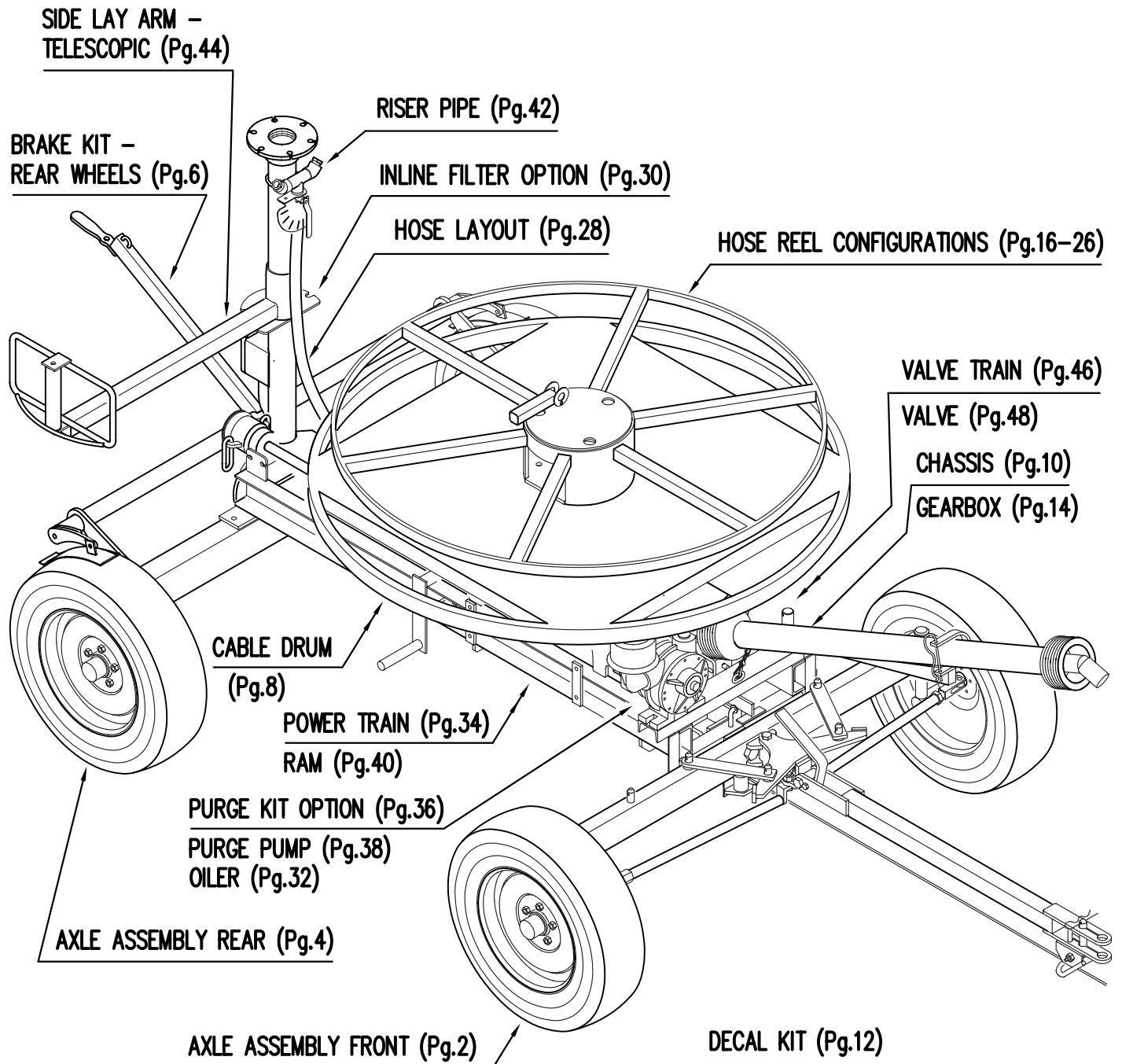

# TRAILCO TRAVELLER T 250-2

MODEL : G

SERIAL No. : 9211 ONWARDS

PART No. : 17951

DATE : 2NOV2005

## AXLE ASSEMBLY FRONT

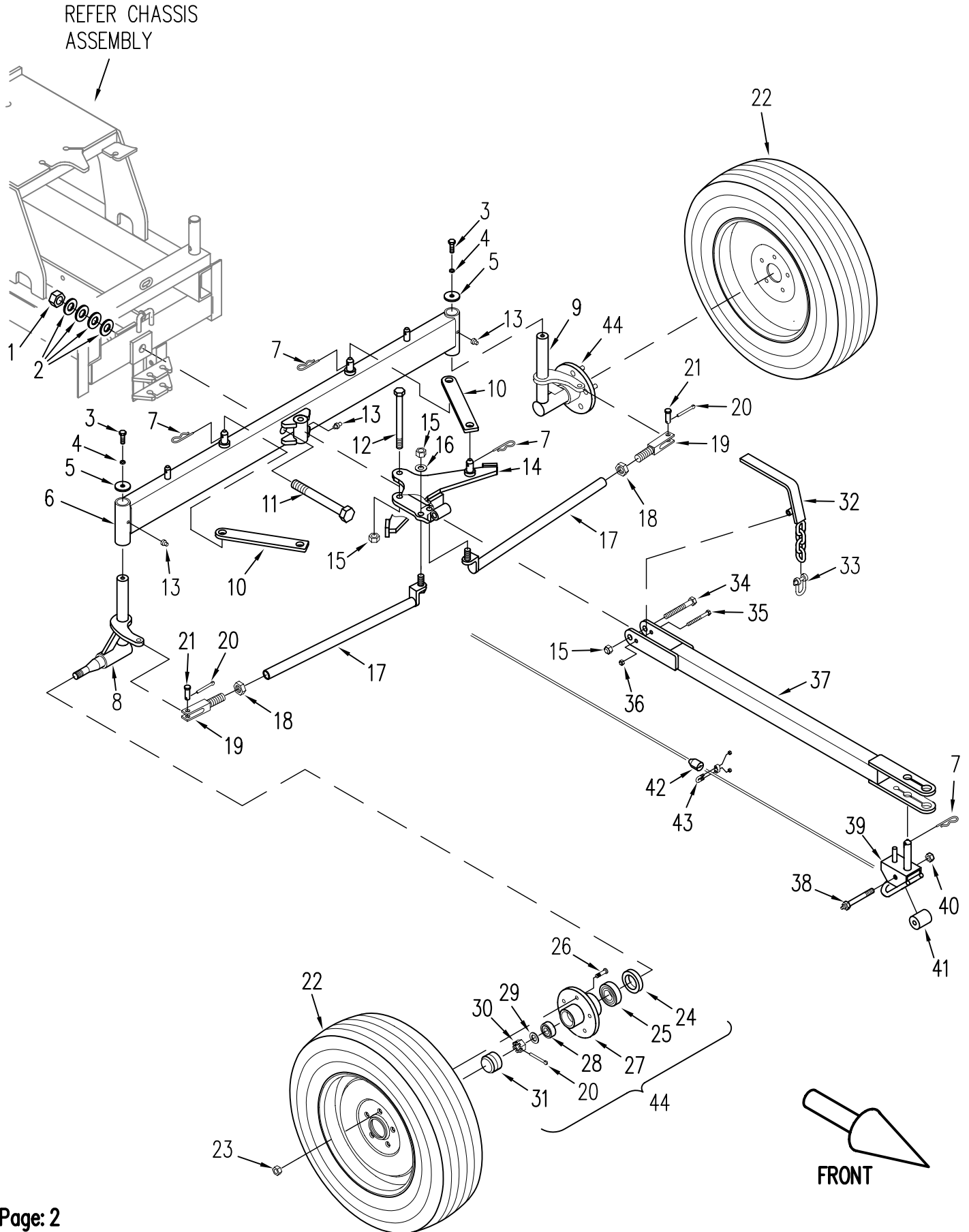



# TRAILCO TRAVELLER

# PARTS LIST

## T 250-2

## MODEL G

SERIAL No's : 9201 ONWARDS

SECTION : AXLE ASSEMBLY FRONT		PART No. : 17951		15-Oct-07
KEY	DESCRIPTION	PART No.	QTY	DWG No.
1	NUT NYLOC M24	BN344	1	
2	WASHER FLAT 1" BRIGHT ZP	BW144	4	
3	BOLT 1" X 3/8" HEX BSW ZP	BN123	2	
4	WASHER SPRING 10MM ZP	BN358	2	
5	RETAINER WASHER KING PIN	23	2	
6	AXLE FRONT	15980	1	
7	CLIP SPRING	B107	5	
8	FRONT STUB RIGHT HAND (14" WHEEL)	551	1	
	FRONT STUB RIGHT HAND (15" WHEEL)	18966		
9	FRONT STUB LEFT HAND (14" WHEEL)	552	1	
	FRONT STUB LEFT HAND (15" WHEEL)	18969		
10	STEERING REV ARM	15996	2	
11	BOLT M24 X 190MM HEX ZP	15978	1	
12	BOLT M16 X 140MM HEX ZP	BN331	1	
13	NIPPLE GREASE	B106	4	
14	STEERING PIVOT	15985	1	
15	NUT NYLOC M16 HEX ZP	15836	4	
16	WASHER FLAT 5/8" BRIGHT ZP	BW145	2	
17	STEERING ROD	15992	2	
18	NUT LOCK 7/8" HEX UNF ZP	BN353	2	
19	CLEVIS YOKE	360	2	
20	PIN SPLIT STEEL 3.2MM X 32MM ZP	BP133	4	
21	CLEVIS PIN	113	2	
22	WHEEL & TYRE ASSEMBLY (14" WHEEL)	85	2	
	WHEEL & TYRE ASSEMBLY (15" WHEEL)	270		
23	WHEEL NUT	18957	10	
24	SEAL	BS81	2	
25	BEARING CONE & CUP (INNER)	BB77	2	
26	WHEEL STUD	18956	10	
27	HUB WITH STUDS AND NUTS	B83	2	
28	BEARING CONE & CUP (OUTER)	BB79	2	
29	WASHER FLAT 20MM X 2MM BRT ZP	BW154	2	
30	NUT SLOTTED 3/4" UNF	BN109	2	
31	GREASE CAP	B84	2	
32	TRIP LEVER	612	1	
33	SHACKLE "D" 3/8" X 3/8"	B616	1	
34	BOLT M16 X 110MM GRADE 8.8 ZP	15976	1	
35	BOLT 3/2" X 3/8" HEX BSW ZP	BN231	1	
36	NUT CONELOCK 3/8" BSW ZP	BN138	1	
37	DRAWBAR	18074	1	
38	BOLT, GUIDE ROLLER	172	1	
39	SKID ROLLER BRACKET	609	1	
40	NUT NYLOC 1/2" BSW	BN139	1	
41	CABLE GUIDE ROLLER	64	1	
42	CABLE BULLET	295	1	
43	CABLE CLAMP	B91	1	
44	HUB ASSEMBLY (LESS KEY No's 20,29,30)	18955	1	

PLEASE QUOTE **MODEL** AND **SERIAL NUMBER** OF IRRIGATOR WHEN ORDERING PARTS

Trailco Irrigation (Aust.) Phone: (07) 3260 1828 Fax: (07) 3260 1877

# TRAILCO TRAVELLER T 250-2

MODEL : G

SERIAL No. : 9201 ONWARDS

PART No. : 17102

DATE : 2NOV2005

## AXLE ASSEMBLY REAR

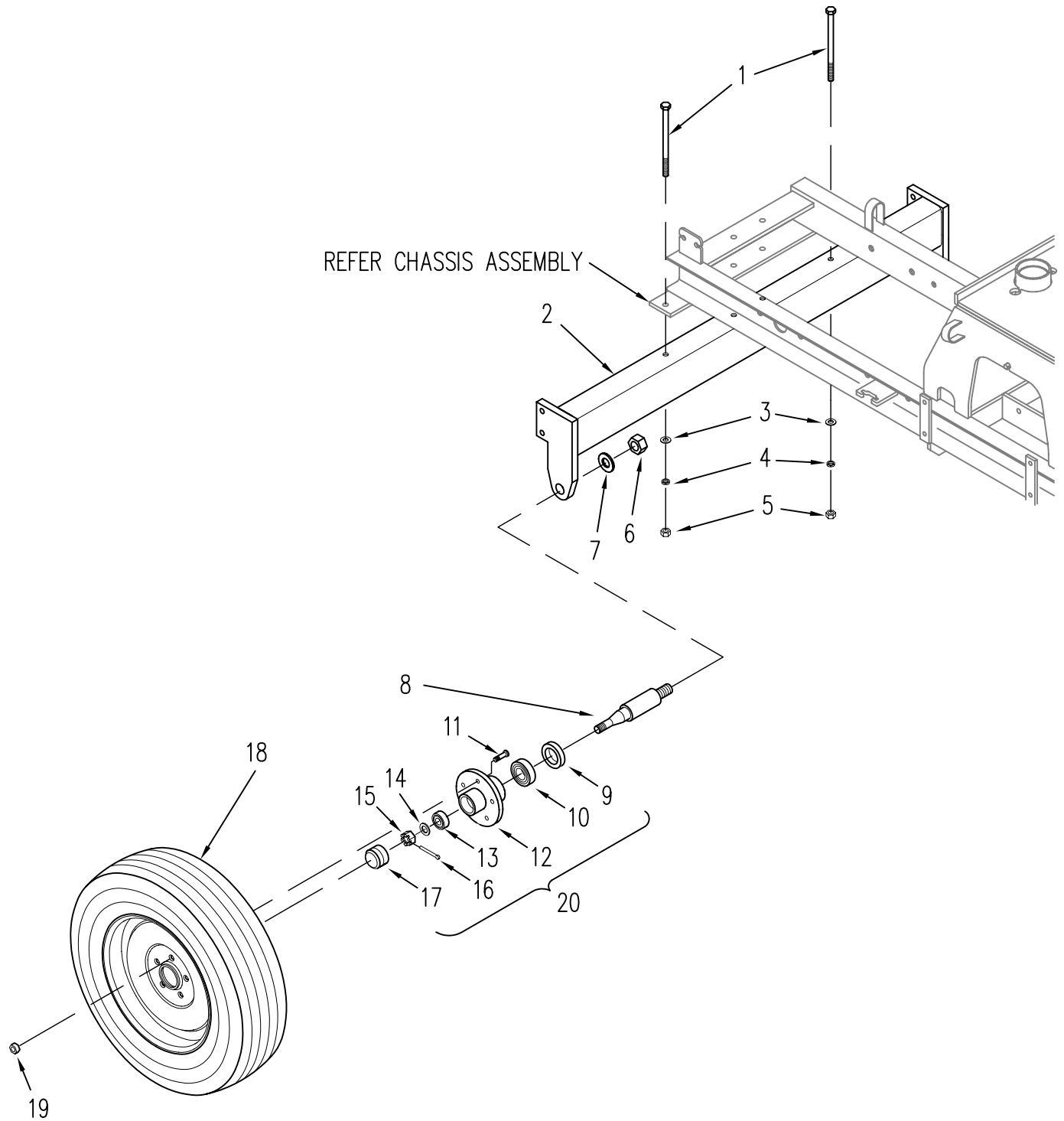



# TRAILCO TRAVELLER

# PARTS LIST

## T 250-2

### MODEL G

SERIAL No's : 9201 ONWARDS

SECTION : AXLE ASSEMBLY REAR		PART No. : 17102		15-Oct-07
KEY	DESCRIPTION	PART No.	QTY	DWG No.
1	BOLT 6" X 1/2" BSW ZP	BN467	2	
2	AXLE REAR	9661	1	
3	WASHER FLAT 1/2" ZP	BW135	2	
4	WASHER SPRING 1/2" ZP	BW118	2	
5	NUT 1/2" BSW ZP	BN117	2	
6	NUT REAR STUB RETAINER	197	2	
7	WASHER FLAT 1" BRT ZP	BW144	2	
8	STUB AXLE REAR (14" WHEEL)	622	2	
	STUB AXLE REAR (15" WHEEL)	18971		
9	SEAL	BS81	2	
10	BEARING CONE & CUP (INNER)	BB77	2	
11	WHEEL STUD	18956	10	
12	HUB WITH STUDS AND NUTS	B83	2	
13	BEARING CONE & CUP (OUTER)	BB79	2	
14	WASHER FLAT 20MM X 2MM BRT ZP	BW154	2	
15	NUT SLOTTED 3/4" UNF	BN109	2	
16	PIN SPLIT STEEL 3.2MM X 32MM ZP	BP133	2	
17	GREASE CAP	B84	2	
18	WHEEL AND TYRE ASSEMBLY (14" WHEEL)	85	2	
	WHEEL AND TYRE ASSEMBLY (15" WHEEL)	270		
19	WHEEL NUT	18957	10	
20	HUB ASSEMBLY (LESS KEY No's 14-16)	18955	2	

PLEASE QUOTE **MODEL** AND **SERIAL NUMBER** OF IRRIGATOR WHEN ORDERING PARTS

Trailco Irrigation (Aust.) Phone: (07) 3260 1828 Fax: (07) 3260 1877







# TRAILCO TRAVELLER

# PARTS LIST

## T 250-2

## MODEL G

SERIAL No's : 9201 ONWARDS

SECTION : BRAKE KIT - REAR WHEELS		PART No. : 9454		15-Oct-07
KEY	DESCRIPTION	PART No.	QTY	DWG No.
1	BRAKE PIPE ASSY	555	1	
2	BRAKE PAD ARM	563	1	
3	BRAKE SHOE	556	2	
4	REAR WHEEL BRAKE RATCHET	557	1	
5	REAR BRAKE PIVOT PLATE	549	2	
6	KEEPER PLATE	564	4	
7	SPRING STRAP (CHAIN)	17176	1	
8	SPRING	BX297	1	
9	NUT 3/8 BSW ZP	BN146	2	
10	TURNBUCKLE	B399	1	
11	BOLT 1" X 3/8" BSW ZP	BN123	3	
12	NUT CONELOCK 3/8" BSW ZP	BN138	3	
13	BOLT 1 3/4" X 1/2" BSW ZP	BN116	1	
14	WASHER FLAT 1/2" ZP	BW135	1	
15	WASHER SPRING 1/2" ZP	BW118	7	
16	NUT 1/2" BSW ZP	BN117	7	
17	BOLT 1 1/2" X 3/8" BSW ZP	BN124	2	
18	BOLT 2" X 1/2" BSW ZP	BN130	6	
19	NUT NYLOC 1/2" BSW	BN139	1	
20	ADJUSTING ROD	560	1	
21	CLAMP PLATE	561	2	
22	HOSE CARRIER	559	1	
23	WASHER SPRING 10MM ZP	BN358	1	

PLEASE QUOTE **MODEL** AND **SERIAL NUMBER** OF IRRIGATOR WHEN ORDERING PARTS

Trailco Irrigation (Aust.) Phone: (07) 3260 1828 Fax: (07) 3260 1877

# TRAILCO TRAVELLER T 250-2

MODEL : G

SERIAL No. : 9201 ONWARDS

PART No. : 17954

DATE : 2NOV2005

## CABLE DRUM ASSEMBLY

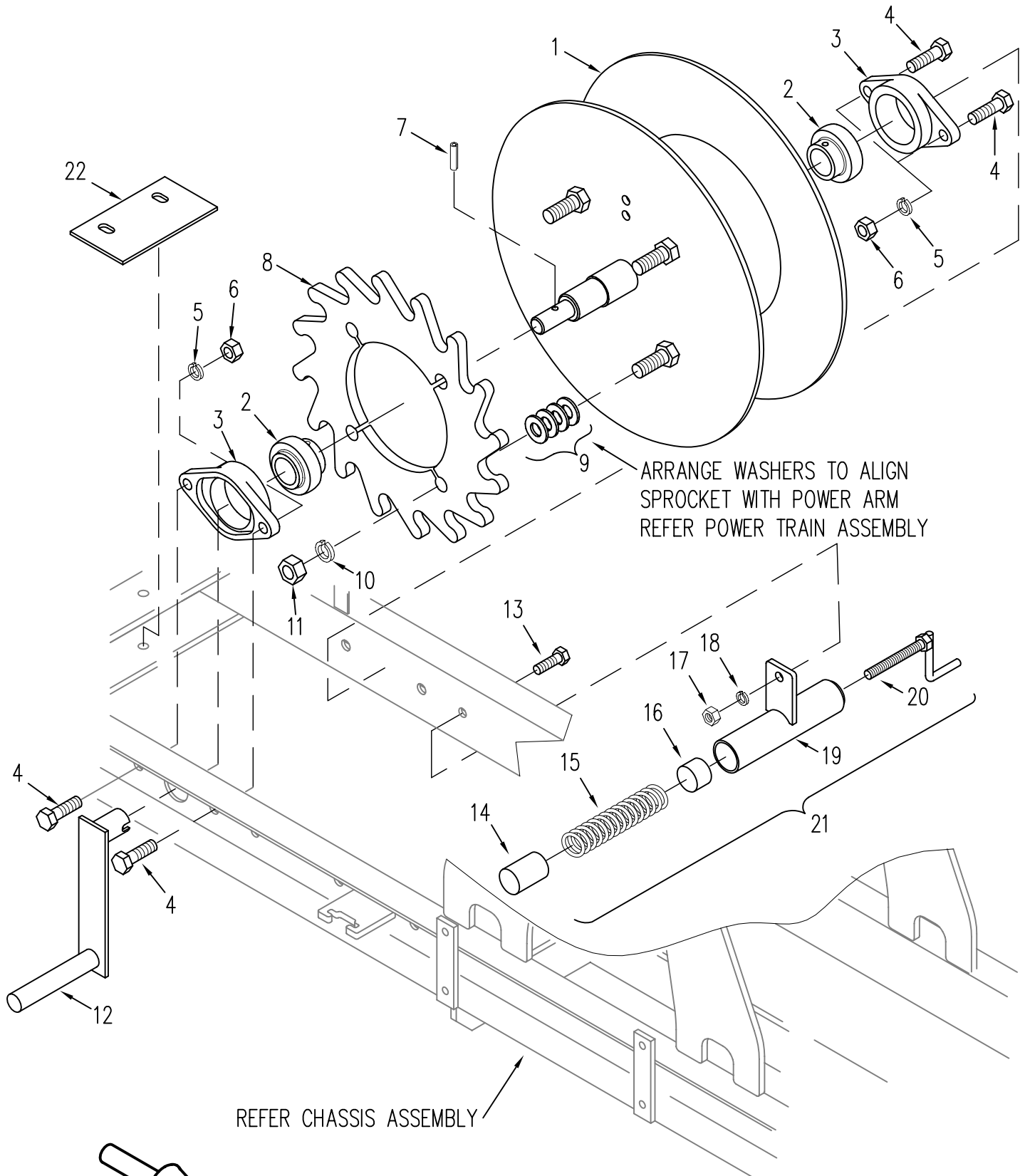

FRONT



# TRAILCO TRAVELLER

# PARTS LIST

## T 250-2

### MODEL G

SERIAL No's : 9201 ONWARDS

SECTION : CABLE DRUM ASSEMBLY		PART No. : 17954		15-Oct-07
KEY	DESCRIPTION	PART No.	QTY	DWG No.
1	CABLE DRUM	18050	1	
2	BEARING ROCKER & CABLE DRUM	18002	2	
3	BEARING HOUSING ROCKER & DRUM	18003	2	
4	BOLT M16 X 55MM ZP	18004	4	
5	WASHER SPRING 5/8" ZP	BW110	4	
6	NUT M16 ZP	BN351	4	
7	CABLE DRUM WIND PIN	18021	1	
8	CABLE DRUM SPROCKET	18057	1	
9	WASHER FLAT 20MM X 2MM BRT ZP	BW154	16	
10	WASHER SPRING M20	B497	4	
11	NUT M20 ZP	11455	4	
12	CABLE DRUM REWIND HANDLE	18064	1	
13	BOLT 1¼" X ½" BSW ZP	BN115	1	
14	NYLON BLOCK	B263	1	
15	SPRING	BX237	1	
16	BRAKE BLOCK	951	1	
17	NUT ½" BSW ZP	BN117	1	
18	WASHER SPRING ½" ZP	BW118	1	
19	BRAKE BODY	5931	1	
20	BRAKE HANDLE	950	1	
21	CABLE DRUM BRAKE ASSEMBLY	593	1	
22	CABLE DRUM WIRE KEEPER	18055	1	

PLEASE QUOTE **MODEL** AND **SERIAL NUMBER** OF IRRIGATOR WHEN ORDERING PARTS

Trailco Irrigation (Aust.) Phone: (07) 3260 1828 Fax: (07) 3260 1877

# TRAILCO TRAVELLER T 250-2

MODEL : G

SERIAL No. : 9201 ONWARDS

PART No. : 17950

DATE : 2NOV2005

## CHASSIS ASSEMBLY

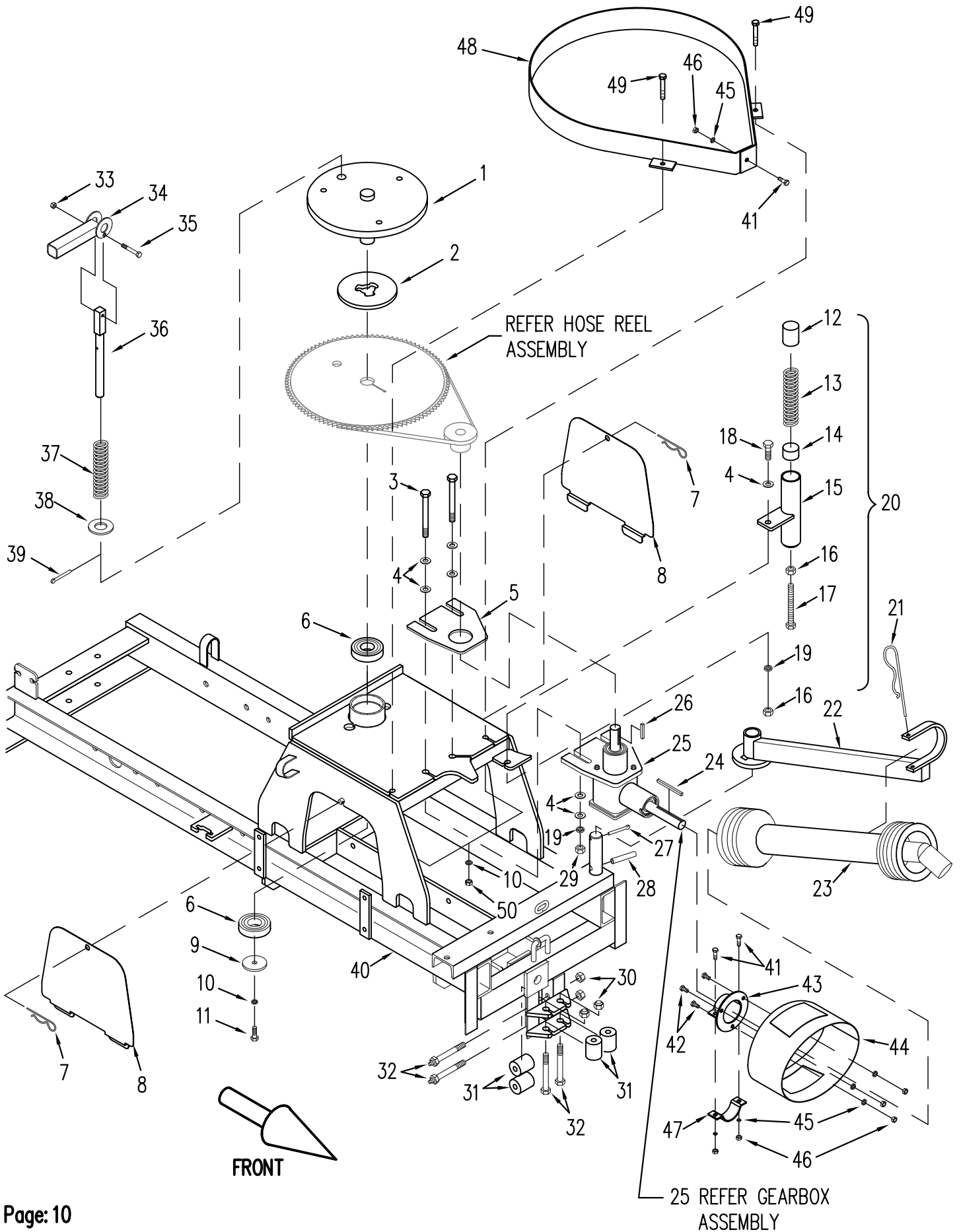



# TRAILCO TRAVELLER

# PARTS LIST

## T 250-2

## MODEL G

SERIAL No's : 9201 ONWARDS

SECTION : CHASSIS ASSEMBLY		PART No. : 17950		15-Oct-07
KEY	DESCRIPTION	PART No.	QTY	DWG No.
1	SPOOL FLANGE	748	1	
2	SPOOL FLANGE SPACER	331	1	
3	BOLT 4" X 1/2" HT UNF ZP	BN190	2	
4	WASHER FLAT 1/2" ZP	BW135	9	
5	GEARBOX SUPPORT PLATE	170N	1	
6	BEARING	BB24	2	
7	CLIP SPRING	B107	2	
8	SAFETY COVER	18006	2	
9	RETAINER WASHER	23	1	
10	WASHER SPRING 10MM ZP	BN358	3	
11	BOLT 1" X 3/8" BSW ZP	BN123	1	
12	NYLON BLOCK	B263	1	
13	SPRING	BX237	1	
14	BRAKE BLOCK	951	1	
15	BRAKE BODY	5931	1	
16	NUT 1/2" BSW ZP	BN117	2	
17	SET SCREW 4 X 1/2" BSW ZP	BN184	1	
18	BOLT 1 1/4" X 1/2" BSW ZP	BN115	1	
19	WASHER SPRING 1/2" ZP	BW118	3	
20	HOSE REEL BRAKE ASSEMBLY	15857	1	
21	CLIP SPRING	209	1	
22	PTO CARRIER ARM TYPE 2	18071	1	
23	PTO SHAFT	18020	1	
24	KEY 6MM SQ X 85MM	18177	1	
25	GEARBOX 90° TYPE 1	767	1	
26	KEY 6MM SQ X 45MM	18176	1	
27	PIN SPLIT STEEL 6.3MM X 40MM ZP	BP131	1	
28	SELLOC PIN 2" X 1/2"	B310	1	
29	NUT 1/2" STD UNF ZP	BN119	2	
30	NUT NYLOC 1/2" BSW	BN139	4	
31	CABLE GUIDE ROLLER	64	4	
32	BOLT GUIDE ROLLER	172	4	
33	NUT NYLOC 1/4" BSW ZP	BN142	1	
34	CLUTCH PIN HANDLE	210	1	
35	BOLT 1 3/4" X 1/4" HEX BSW ZP	BN122	1	
36	CLUTCH PIN	211	1	
37	SPRING	BX31	1	
38	WASHER FLAT 20mm x 2mm ZP	BW154	1	
39	PIN SPLIT 4MM X 40MM ZP	BP132	1	
40	CHASSIS	18030	1	
41	BOLT M8 X 25MM HEX ZP	11350	3	
42	BOLT M8 X 16MM HEX ZP	16329	3	
43	COVER BRACKET PTO SHAFT ZP	18026	1	
44	PTO COVER - PLASTIC	17498	1	
45	WASHER SPRING 5/16"	BW126	8	
46	NUT M8 HEX ZP	16143	8	
47	COVER BRACKET CLAMP	18028	1	
48	SAFETY COVER	14640	1	
49	BOLT M10 X 65mm ZP	BW356	2	
50	NUT M10 ZP	16053	2	

PLEASE QUOTE **MODEL** AND **SERIAL NUMBER** OF IRRIGATOR WHEN ORDERING PARTS

Trailco Irrigation (Aust.) Phone: (07) 3260 1828 Fax: (07) 3260 1877

# TRAILCO TRAVELLER T 250-2

MODEL : G

SERIAL No. : 9201 ONWARDS

PART No. : 17955

DATE : 2NOV2005

## DECAL KIT

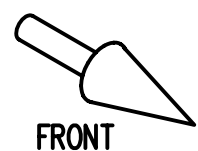
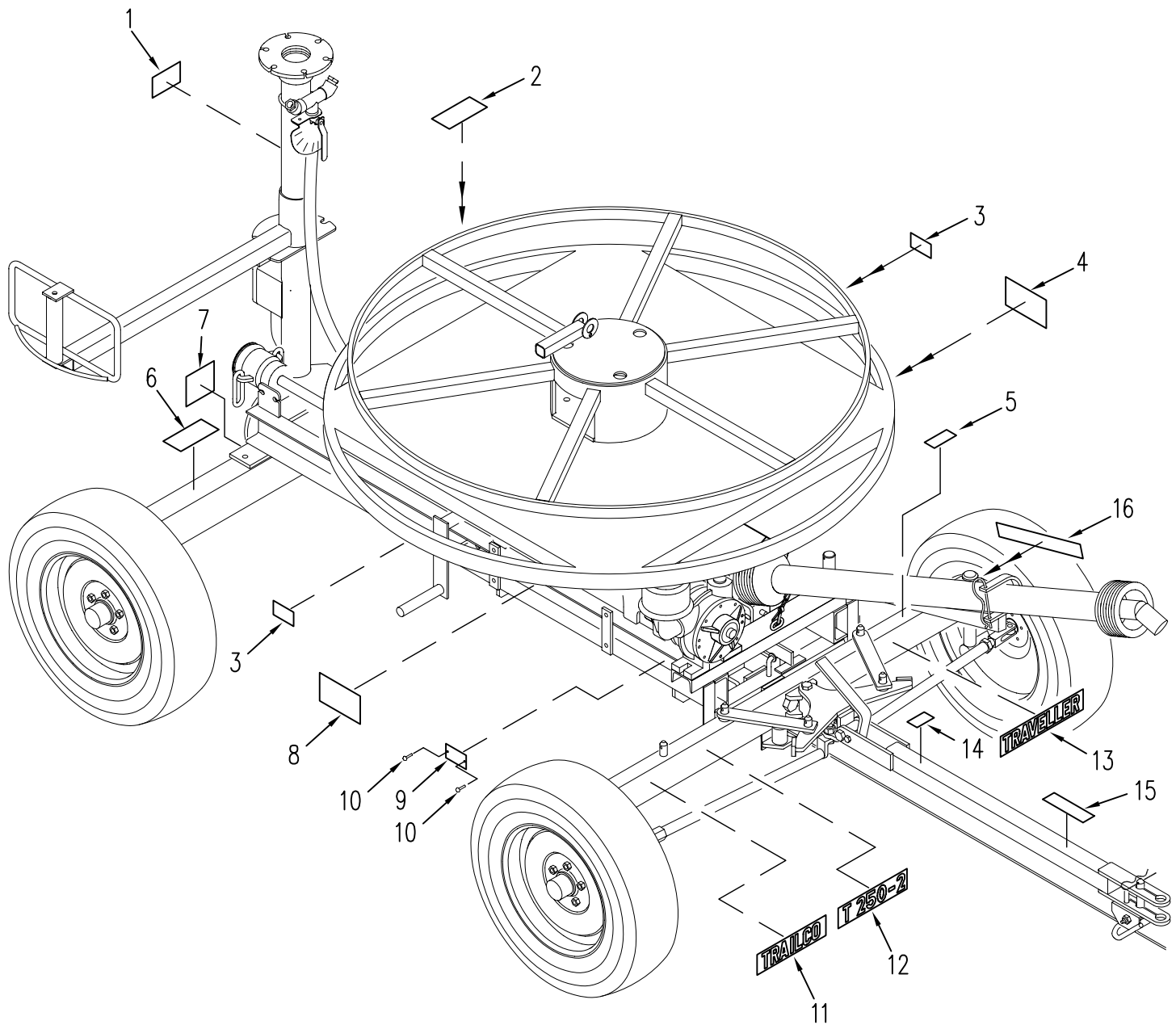



# TRAILCO TRAVELLER

# PARTS LIST

## T 250-2

## MODEL G

SERIAL No's : 9201 ONWARDS

SECTION : DECAL KIT		PART No. : 17955		15-Oct-07
KEY	DESCRIPTION	PART No.	QTY	DWG No.
1	STICKER - TRAILCO LOGO MEDIUM	AT25	1	
2	STICKER - "CAUTION DO NOT PULL..."	AT7	1	
3	STICKER - "KEEP CLEAR OF MOVING PARTS"	AT3	2	
4	STICKER - VALVE MODULE LUBRICATION	AT45	1	
5	STICKER - "WARNING DO NOT TOW..."	AT14	1	
6	STICKER - "THIS MACHINE OPERATES AT ..."	AT6	1	
7	STICKER - "NOTICE! WHEN STARTING..."	AT5	1	
8	STICKER - CHASSIS LUBRICATION	AT31	1	
9	STICKER - MODEL/SERIAL No. PLATE	AT1	1	
10	POP RIVET	B39	2	
11	STICKER - "TRAILCO"	AT11	1	
12	STICKER - "T250-2"	AT35	1	
13	STICKER - "TRAVELLER"	AT12	1	
14	STICKER - "STAY CLEAR OF MACHINE..."	AT9	1	
15	STICKER - "TOWING SPEED LIMIT 10kph"	AT64	1	
16	STICKER - "CAUTION REMAIN ON TRACTOR..."	AT62	1	

PLEASE QUOTE **MODEL** AND **SERIAL NUMBER** OF IRRIGATOR WHEN ORDERING PARTS

Trailco Irrigation (Aust.) Phone: (07) 3260 1828 Fax: (07) 3260 1877

# TRAILCO TRAVELLER T 250-2

MODEL : G

SERIAL No. : 9201 ONWARDS

PART No. : 767

DATE : 2NOV2005

## GEARBOX 90° TYPE 1

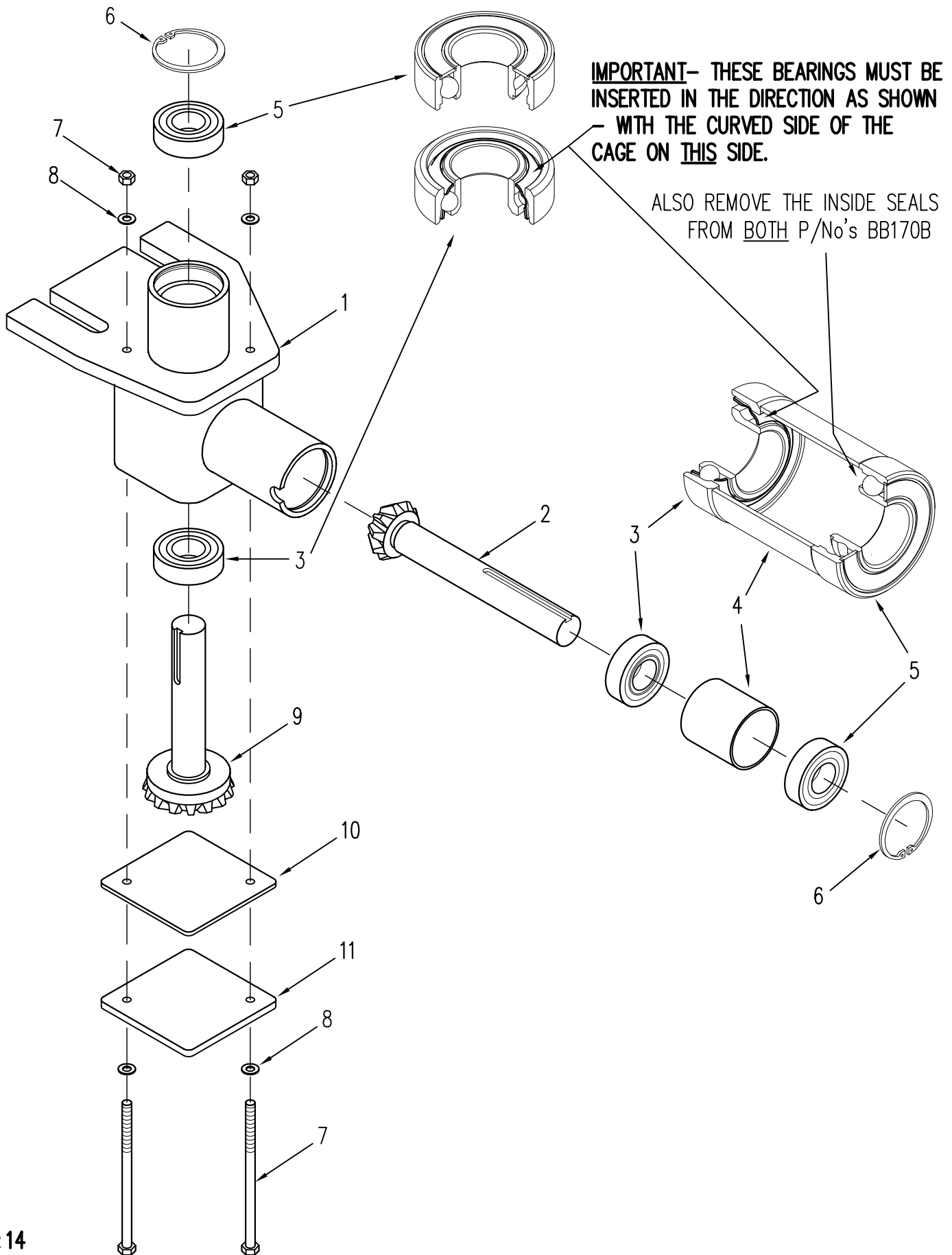





# TRAILCO TRAVELLER

# PARTS LIST

## T 250-2

## MODEL G

**SERIAL No's : 9201 ONWARDS**

SECTION : GEARBOX 90° TYPE 1		PART No. : 767		15-Oct-07
KEY	DESCRIPTION	PART No.	QTY	DWG No.
1	GEARBOX HOUSING	767A	1	
2	INPUT SHAFT & GEAR	772	1	
3	BEARING THRUST	BB170A	2	
4	SPACER TUBE	771	1	
5	BEARING SEALED	BB170B	2	
6	CIRCLIP	BB170F	2	
7	BOLT M6 X 130MM HEX ZP	BN170J	2	
8	WASHER COPPER ¼"	BW100K	4	
9	OUTPUT SHAFT & GEAR	774	1	
10	GASKET	B170K	1	
11	COVER PLATE	761	1	

PLEASE QUOTE **MODEL** AND **SERIAL NUMBER** OF IRRIGATOR WHEN ORDERING PARTS

Trailco Irrigation (Aust.) Phone: (07) 3260 1828 Fax: (07) 3260 1877

# TRAILCO TRAVELLER T 250-2

MODEL : G

SERIAL No. : 9201 ONWARDS

PART No. : 17103

DATE : 2NOV2005

## HOSE REEL - CONFIG 2.5" X 100M HOSE

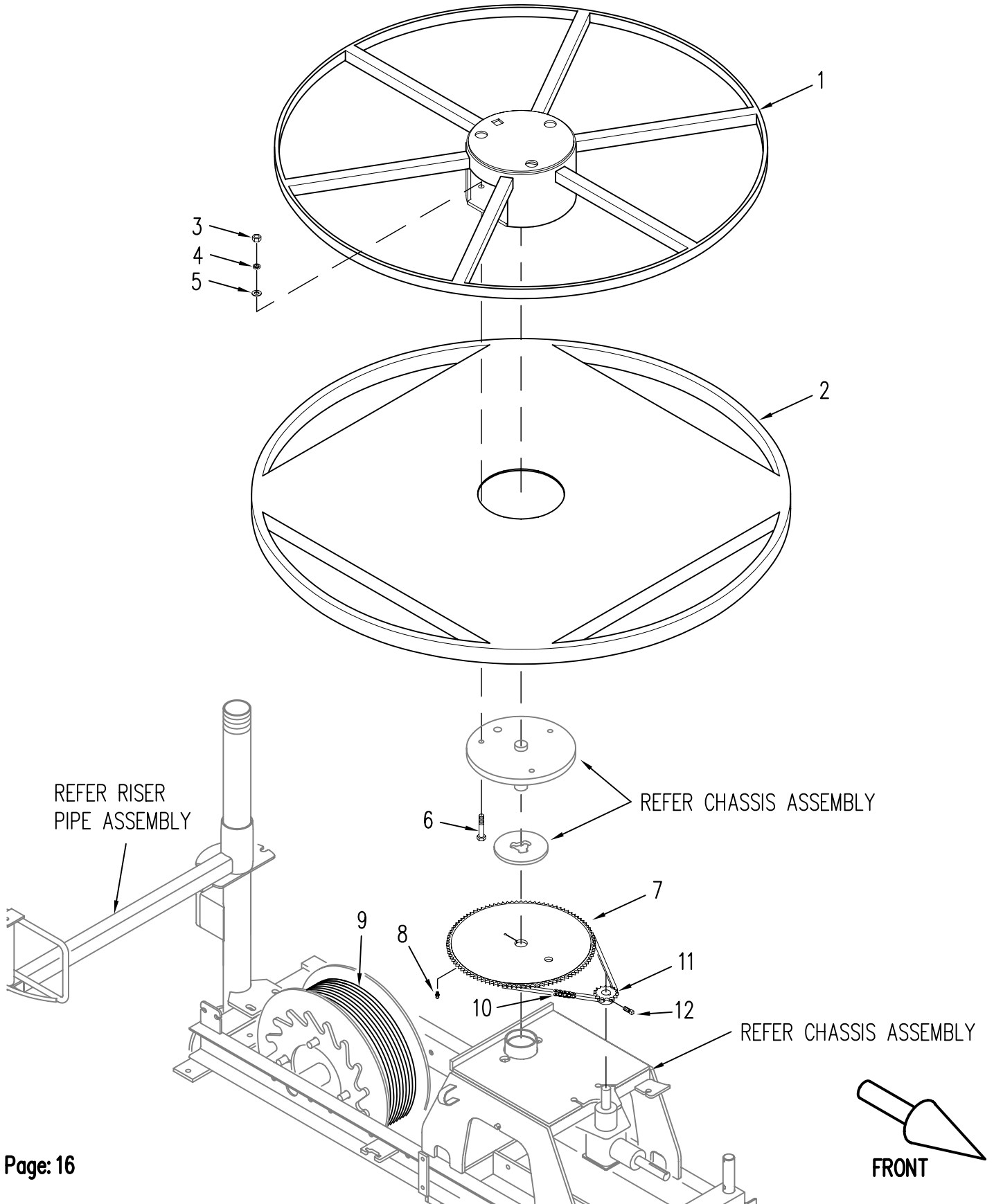



# TRAILCO TRAVELLER

# PARTS LIST

## T 250-2

### MODEL G

SERIAL No's : 9201 ONWARDS

SECTION : HOSE REEL - CONFIG 2½" X 100M HOSE		PART No. : 17103		15-Oct-07
KEY	DESCRIPTION	PART No.	QTY	DWG No.
1	HOSE REEL TOP	248	1	
2	HOSE REEL BASE	243	1	
3	NUT ½" BSW ZP	BN117	3	
4	WASHER SPRING ½" ZP	BW118	3	
5	WASHER FLAT ½" ZP	BW135	3	
6	BOLT 2½" X ½" BSW ZP	BN179	3	
7	SPROCKET	228	1	
8	NIPPLE GREASE ¼" UNF	B106	1	
9	CABLE	B232	1	
10	CHAIN	BS226	1	
11	SPROCKET	BS170D	1	
12	SET SCREW 5/16" SOC/HD BSW ZP	BN434	1	

PLEASE QUOTE **MODEL** AND **SERIAL NUMBER** OF IRRIGATOR WHEN ORDERING PARTS

Trailco Irrigation (Aust.) Phone: (07) 3260 1828 Fax: (07) 3260 1877

# TRAILCO TRAVELLER T 250-2

MODEL : G

SERIAL No. : 9201 ONWARDS

PART No. : 17104

DATE : 2NOV2005

## HOSE REEL - CONFIG 3" X 100M HOSE

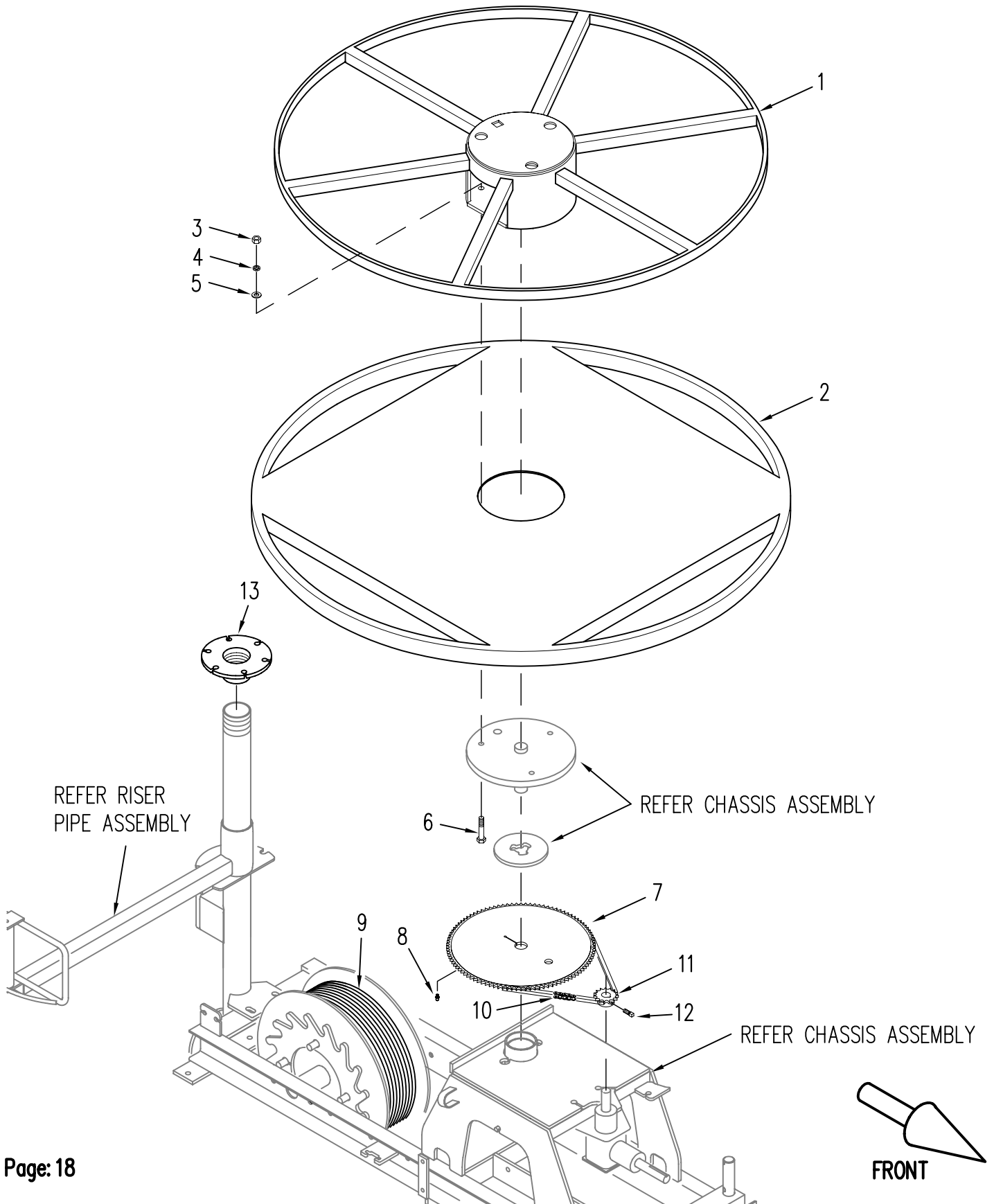



# TRAILCO TRAVELLER

# PARTS LIST

## T 250-2

### MODEL G

SERIAL No's : 9201 ONWARDS

SECTION : HOSE REEL - CONFIG 3" X 100M HOSE		PART No. : 17104		15-Oct-07
KEY	DESCRIPTION	PART No.	QTY	DWG No.
1	HOSE REEL TOP	248	1	
2	HOSE REEL BASE	241	1	
3	NUT ½" BSW ZP	BN117	3	
4	WASHER SPRING ½" ZP	BW118	3	
5	WASHER FLAT ½" ZP	BW135	3	
6	BOLT 2½" X ½" BSW ZP	BN179	3	
7	SPROCKET	228	1	
8	NIPPLE GREASE ¼" UNF	B106	1	
9	CABLE	B232	1	
10	CHAIN	BS226	1	
11	SPROCKET	BS170D	1	
12	SET SCREW 5/16" SOC/HD BSW ZP	BN434	1	
13	FLANGE	249	1	

PLEASE QUOTE **MODEL** AND **SERIAL NUMBER** OF IRRIGATOR WHEN ORDERING PARTS

Trailco Irrigation (Aust.) Phone: (07) 3260 1828 Fax: (07) 3260 1877

# TRAILCO TRAVELLER T 250-2

MODEL : G

SERIAL No. : 9201 ONWARDS

PART No. : 17105

DATE : 2NOV2005

## HOSE REEL - CONFIG 2.5" X 150M HOSE

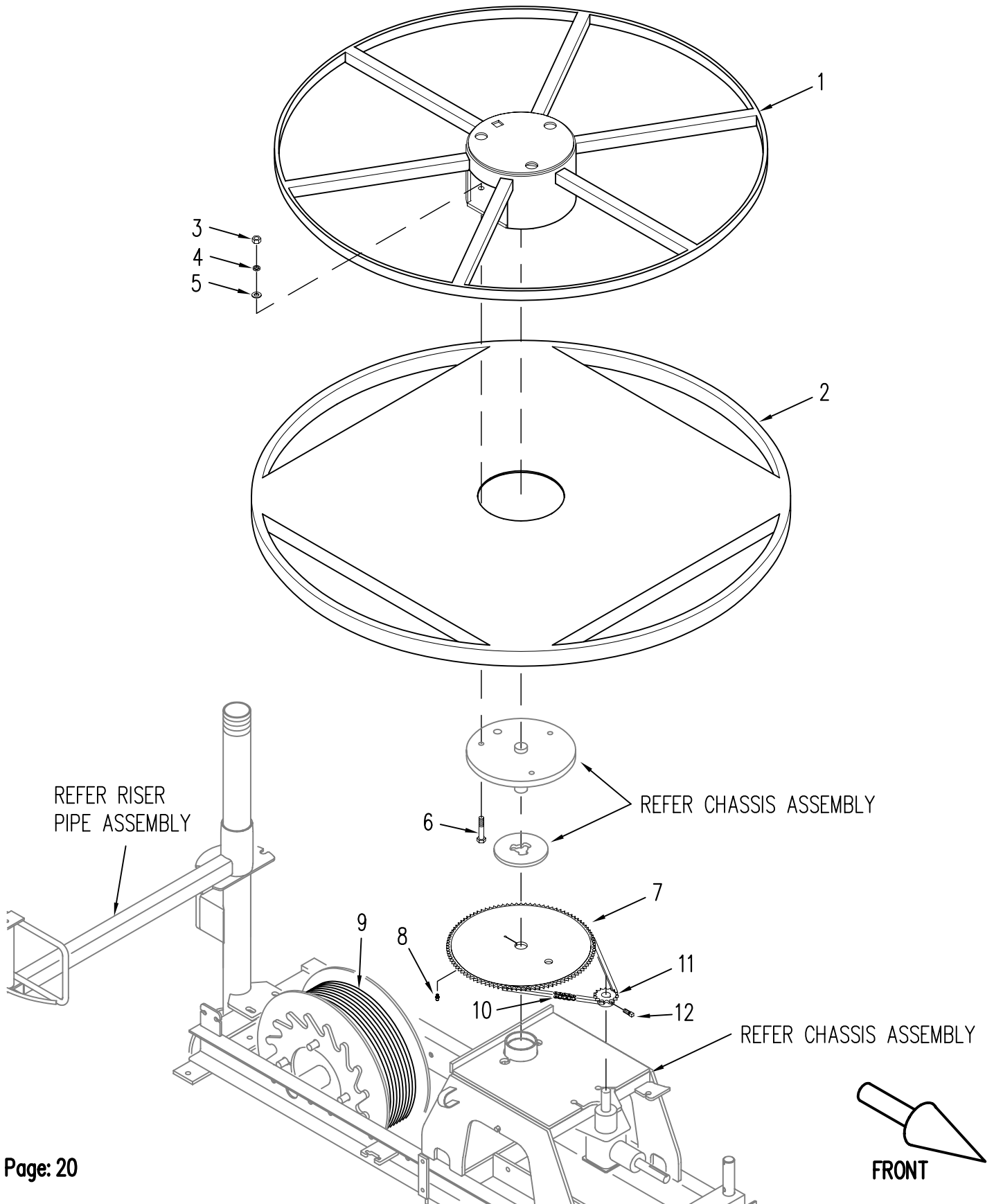



# TRAILCO TRAVELLER

# PARTS LIST

## T 250-2

## MODEL G

SERIAL No's : 9201 ONWARDS

SECTION : HOSE REEL - CONFIG 2½" X 150M HOSE		PART No. : 17105		15-Oct-07
KEY	DESCRIPTION	PART No.	QTY	DWG No.
1	HOSE REEL TOP	248	1	
2	HOSE REEL BASE	241	1	
3	NUT ½" BSW ZP	BN117	3	
4	WASHER SPRING ½" ZP	BW118	3	
5	WASHER FLAT ½" ZP	BW135	3	
6	BOLT 2½" X ½" BSW ZP	BN179	3	
7	SPROCKET	228	1	
8	NIPPLE GREASE ¼" UNF	B106	1	
9	CABLE	B268	1	
10	CHAIN	BS226	1	
11	SPROCKET	BS170D	1	
12	SET SCREW 5/16" SOC/HD BSW ZP	BN434	1	

PLEASE QUOTE **MODEL** AND **SERIAL NUMBER** OF IRRIGATOR WHEN ORDERING PARTS

Trailco Irrigation (Aust.) Phone: (07) 3260 1828 Fax: (07) 3260 1877

# TRAILCO TRAVELLER T 250-2

MODEL : G

SERIAL No. : 9201 ONWARDS

PART No. : 17106

DATE : 2NOV2005

## HOSE REEL - CONFIG 3" X 150M HOSE

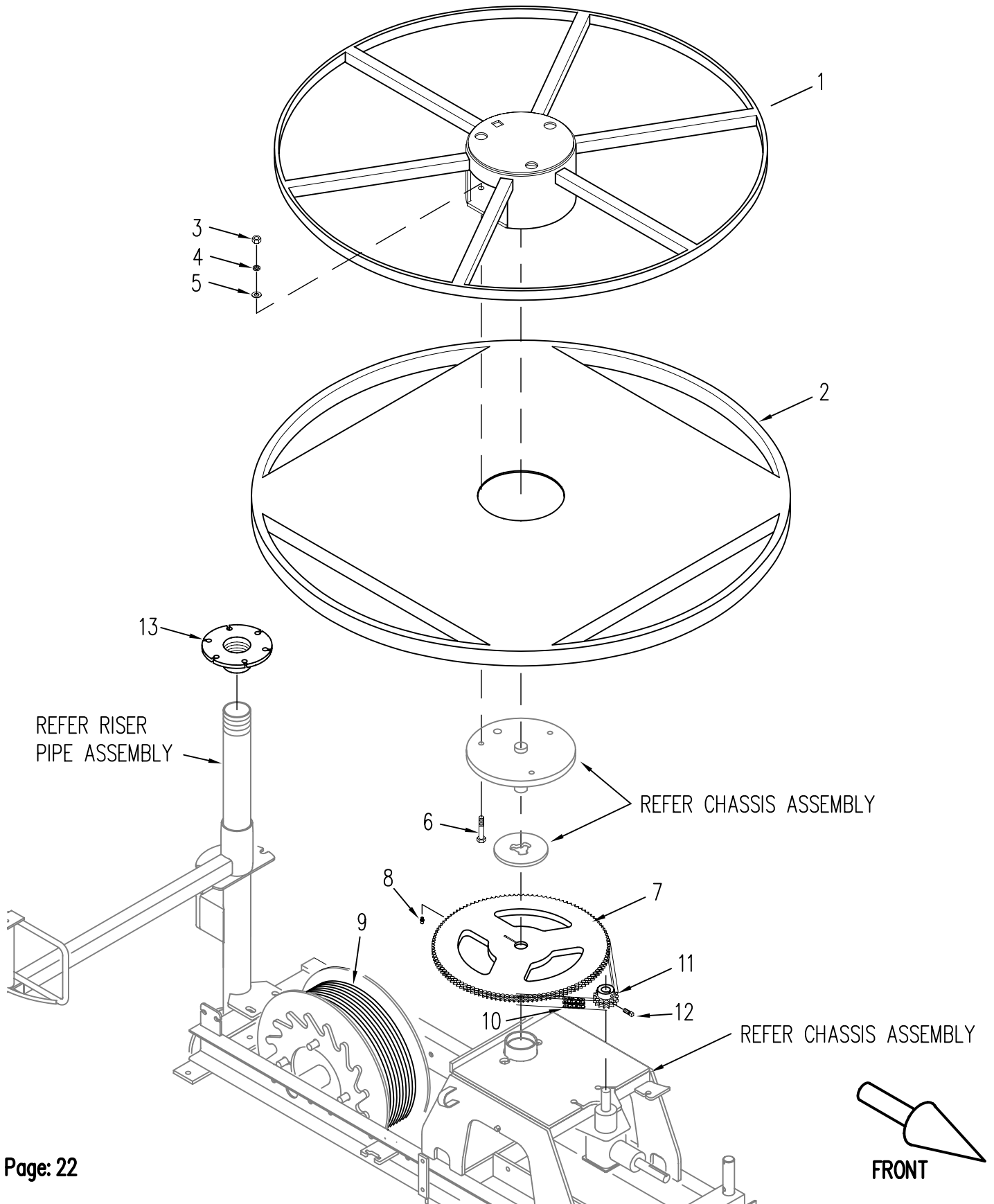





# TRAILCO TRAVELLER

# PARTS LIST

## T 250-2

## MODEL G

SERIAL No's : 9201 ONWARDS

SECTION : HOSE REEL - CONFIG 3" X 150M HOSE		PART No. : 17106		15-Oct-07
KEY	DESCRIPTION	PART No.	QTY	DWG No.
1	HOSE REEL TOP	17080	1	
2	HOSE REEL BASE	241	1	
3	NUT ½" BSW ZP	BN117	3	
4	WASHER SPRING ½" ZP	BW118	3	
5	WASHER FLAT ½" ZP	BW135	3	
6	BOLT 2½" X ½" BSW ZP	BN179	3	
7	SPROCKET	285	1	
8	NIPPLE GREASE ¼" UNF STRAIGHT	B106	1	
9	CABLE	B268	1	
10	CHAIN	BS287	1	
11	SPROCKET	BS286	1	
12	SET SCREW 5/16" SOC/HD BSW ZP	BN434	1	
13	RISER PIPE FLANGE	249	1	

PLEASE QUOTE **MODEL** AND **SERIAL NUMBER** OF IRRIGATOR WHEN ORDERING PARTS

Trailco Irrigation (Aust.) Phone: (07) 3260 1828 Fax: (07) 3260 1877

# TRAILCO TRAVELLER T 250-2

MODEL : G

SERIAL No. : 9201 ONWARDS

PART No. : 17107

DATE : 2NOV2005

## HOSE REEL - CONFIG 2.5" X 200M HOSE

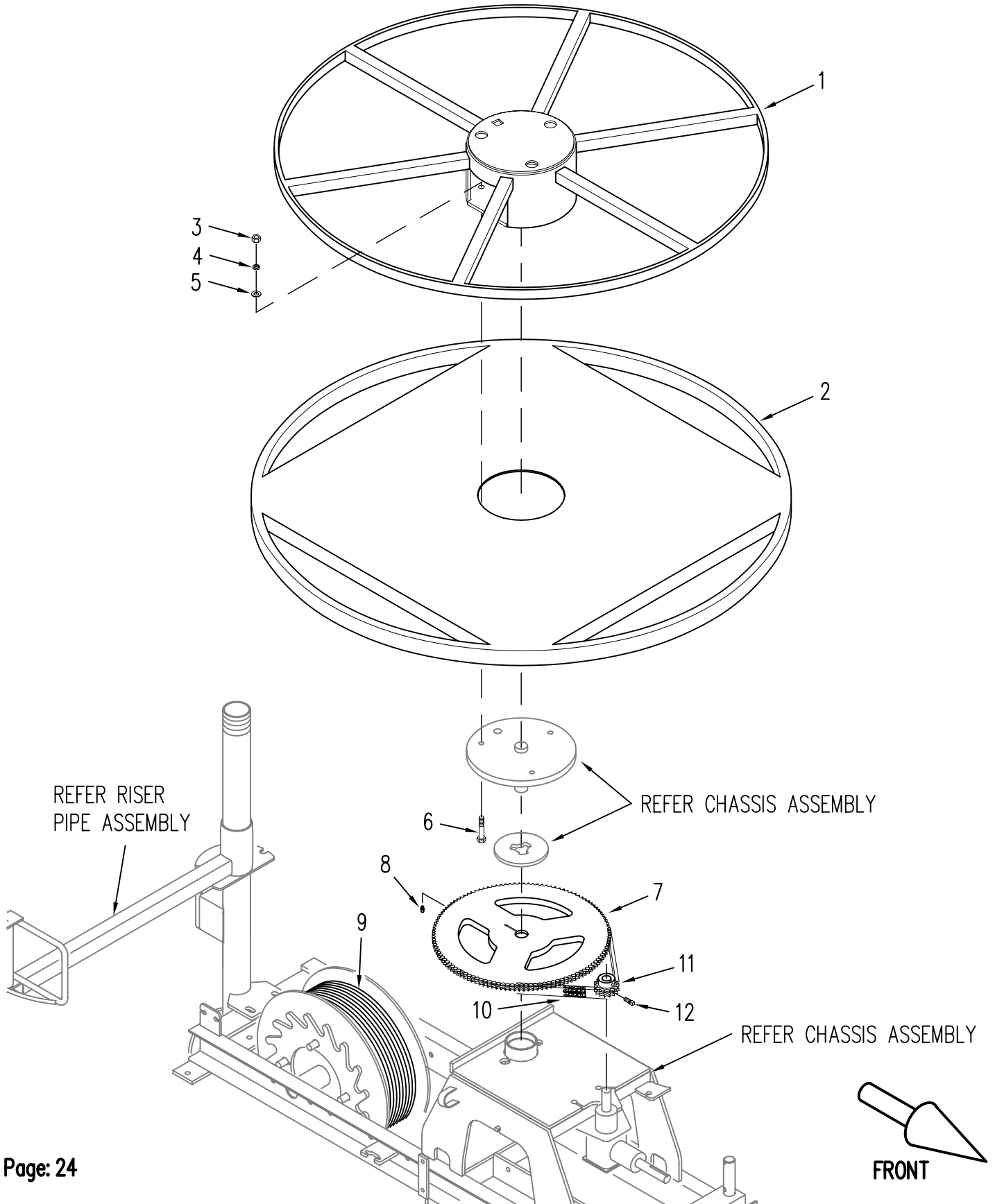



# TRAILCO TRAVELLER

# PARTS LIST

## T 250-2

### MODEL G

SERIAL No's : 9201 ONWARDS

SECTION : HOSE REEL - CONFIG 2½" X 200M HOSE		PART No. : 17107		15-Oct-07
KEY	DESCRIPTION	PART No.	QTY	DWG No.
1	HOSE REEL TOP	17080	1	
2	HOSE REEL BASE	241	1	
3	NUT ½" BSW ZP	BN117	3	
4	WASHER SPRING ½" ZP	BW118	3	
5	WASHER FLAT ½" ZP	BW135	3	
6	BOLT 2½" X ½" BSW ZP	BN179	3	
7	SPROCKET	285	1	
8	NIPPLE GREASE ¼" UNF	B106	1	
9	CABLE	B232A	1	
10	CHAIN	BS287	1	
11	SPROCKET	BS286	1	
12	SET SCREW 5/16" SOC/HD BSW ZP	BN434	1	

PLEASE QUOTE **MODEL** AND **SERIAL NUMBER** OF IRRIGATOR WHEN ORDERING PARTS

Trailco Irrigation (Aust.) Phone: (07) 3260 1828 Fax: (07) 3260 1877

# TRAILCO TRAVELLER T 250-2

MODEL : G

SERIAL No. : 9201 ONWARDS

PART No. : 17108

DATE : 2NOV2005

## HOSE REEL - CONFIG 3" X 200M HOSE

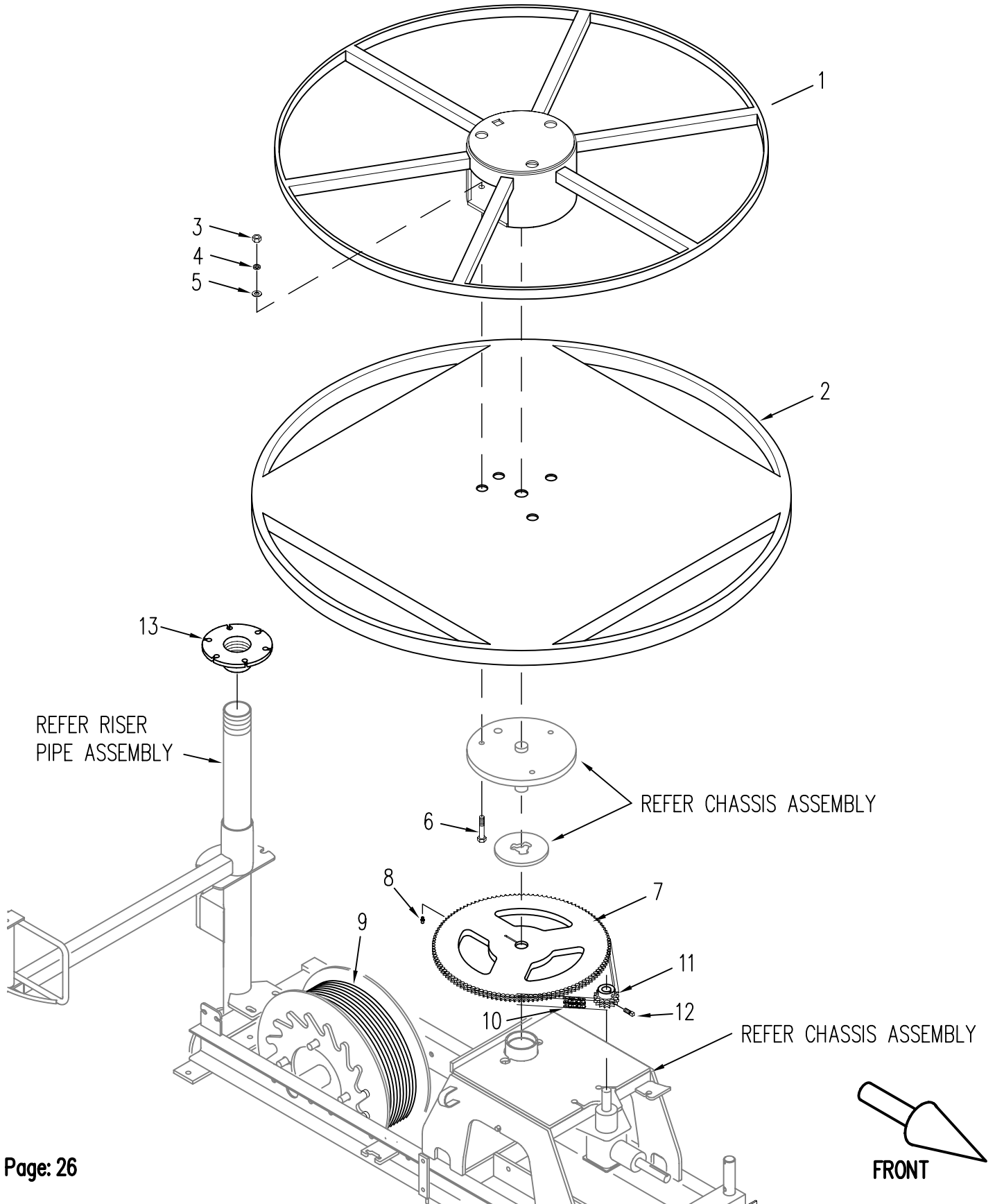



# TRAILCO TRAVELLER

# PARTS LIST

## T 250-2

### MODEL G

SERIAL No's : 9201 ONWARDS

SECTION : HOSE REEL - CONFIG 3" X 200M HOSE		PART No. : 17108		15-Oct-07
KEY	DESCRIPTION	PART No.	QTY	DWG No.
1	HOSE REEL TOP	17080	1	
2	HOSE REEL BASE	242	1	
3	NUT ½" UNF ZP	BN119	3	
4	WASHER SPRING ½" ZP	BW118	3	
5	WASHER FLAT ½" ZP	BW135	3	
6	BOLT 2½" X ½" HT HEX UNF ZP	BN161	3	
7	SPROCKET	285	1	
8	NIPPLE GREASE ¼" UNF STRAIGHT	B106	1	
9	CABLE	B229	1	
10	CHAIN	BS287	1	
11	SPROCKET	BS286	1	
12	SET SCREW 5/16" SOC/HD BSW ZP	BN434	1	
13	RISER PIPE FLANGE	249	1	

PLEASE QUOTE **MODEL** AND **SERIAL NUMBER** OF IRRIGATOR WHEN ORDERING PARTS

Trailco Irrigation (Aust.) Phone: (07) 3260 1828 Fax: (07) 3260 1877





# TRAILCO TRAVELLER

# PARTS LIST

## T 250-2

## MODEL G

**SERIAL No's : 9201 ONWARDS**

SECTION : HOSE LAYOUT		PART No. : 17956	
		15-Oct-07	
KEY	DESCRIPTION	PART No.	QTY
1	HOSE CLIP 1" HOSE SS	BH59	12
2	HOSE 1" - EXHAUST MANIFOLD TO EXHAUST		2100mm
3	HOSE 1" - INLET TO VALVE		2100mm
4	HOSE 1" - VALVE TO EXHAUST MANIFOLD		2 x 150mm
5	HOSE 1" - RAM TOP TO VALVE		570mm
6	HOSE 1" - RAM BOTTOM TO VALVE		500mm
ALL HOSE IS 1" TYPE "S" YELLOW			

PLEASE QUOTE **MODEL** AND **SERIAL NUMBER** OF IRRIGATOR WHEN ORDERING PARTS

Trailco Irrigation (Aust.) Phone: (07) 3260 1828 Fax: (07) 3260 1877

# TRAILCO TRAVELLER T 250-2

MODEL : G

SERIAL No. : 9201 ONWARDS

PART No. : 17437

DATE : 2NOV2005

## INLINE FILTER OPTION

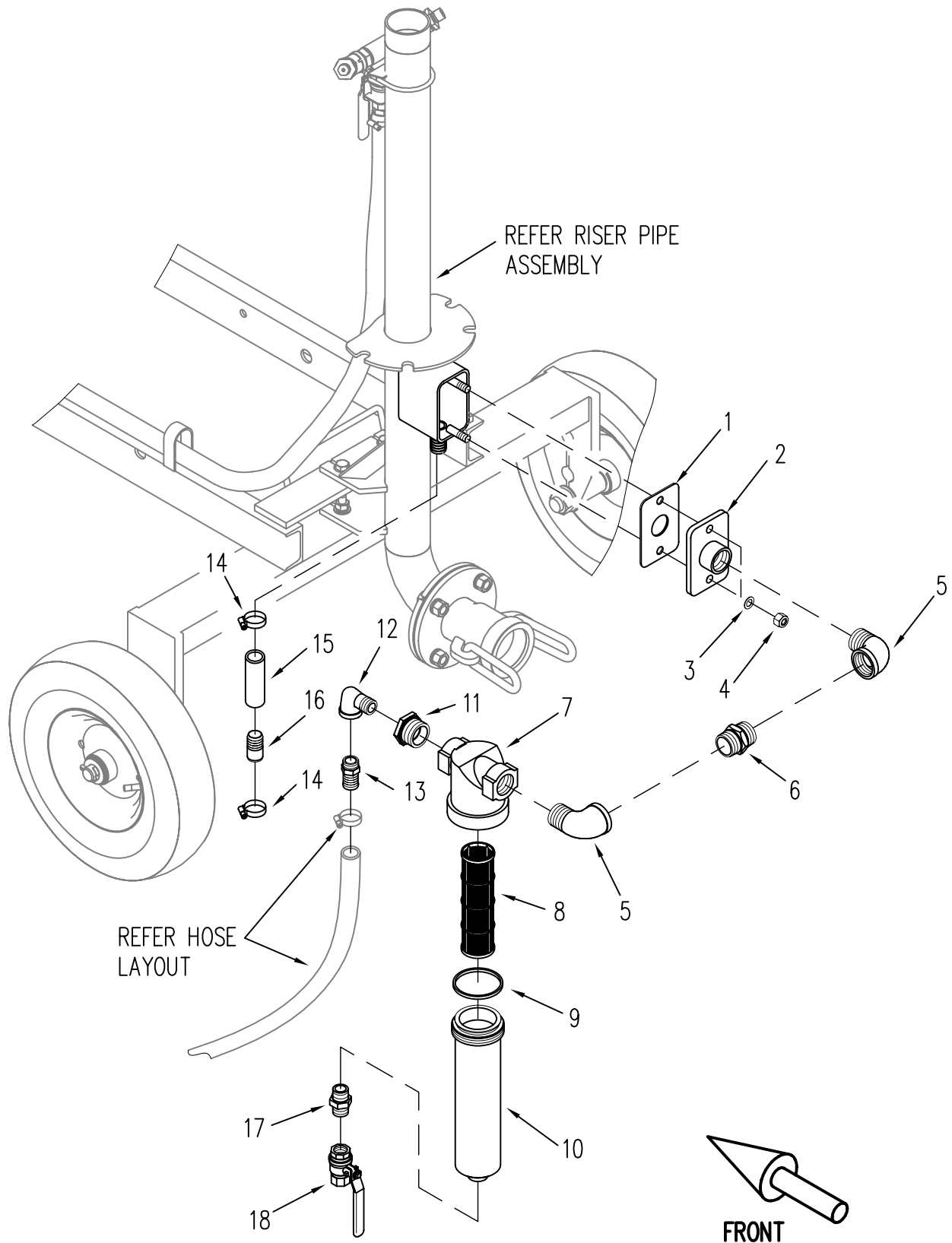





# TRAILCO TRAVELLER

# PARTS LIST

## T 250-2

### MODEL G

SERIAL No's : 9201 ONWARDS

SECTION: INLINE FILTER OPTION		PART No. : 17437		15-Oct-07	
KEY	DESCRIPTION	PART No.	QTY	DWG No.	
1	GASKET INLINE FILTER BOX COVER	990	1		
2	FILTER BOX COVER PL INLINE ZP	973	1		
3	WASHER COPPER 1/2"x7/8"x1/32"	BW67	2		
4	NUT NYLOC 1/2" BSW	BN139	2		
5	ELBOW 1 1/4"90D M&F GAL MAL	BF314	2		
6	NIPPLE HEX 1 1/4" GAL MAL	BF319	1		
7	FILTER CAP	BF823	1		
8	SCREEN	17034	1		
9	SEAL	17035	1		
10	FILTER BOWL INLINE LONG ZP	9961	1		
11	BUSH RED 1 1/4" X 3/4" GAL MAL	BF424	1		
12	ELBOW 3/4" 90D M&F GAL MAL	BF41E	1		
13	HOSE TAIL 3/4" BRASS BARBED	65	1		
14	HOSE CLIP 1" HOSE SS	BH59	2		
15	HOSE 1" TYPE "S" YELLOW	BH102	100mm		
16	PLUG	18178	1		
17	NIPPLE HEX 3/4" GAL MAL	BF41B	1		
18	VALVE BALL 20mm	BF40	1		

PLEASE QUOTE **MODEL** AND **SERIAL NUMBER** OF IRRIGATOR WHEN ORDERING PARTS

Trailco Irrigation (Aust.) Phone: (07) 3260 1828 Fax: (07) 3260 1877

# TRAILCO TRAVELLER T 250-2

MODEL : G

SERIAL No. : 9201 ONWARDS

PART No. : 7

DATE : 2NOV2005

## OILER ASSEMBLY SMALL

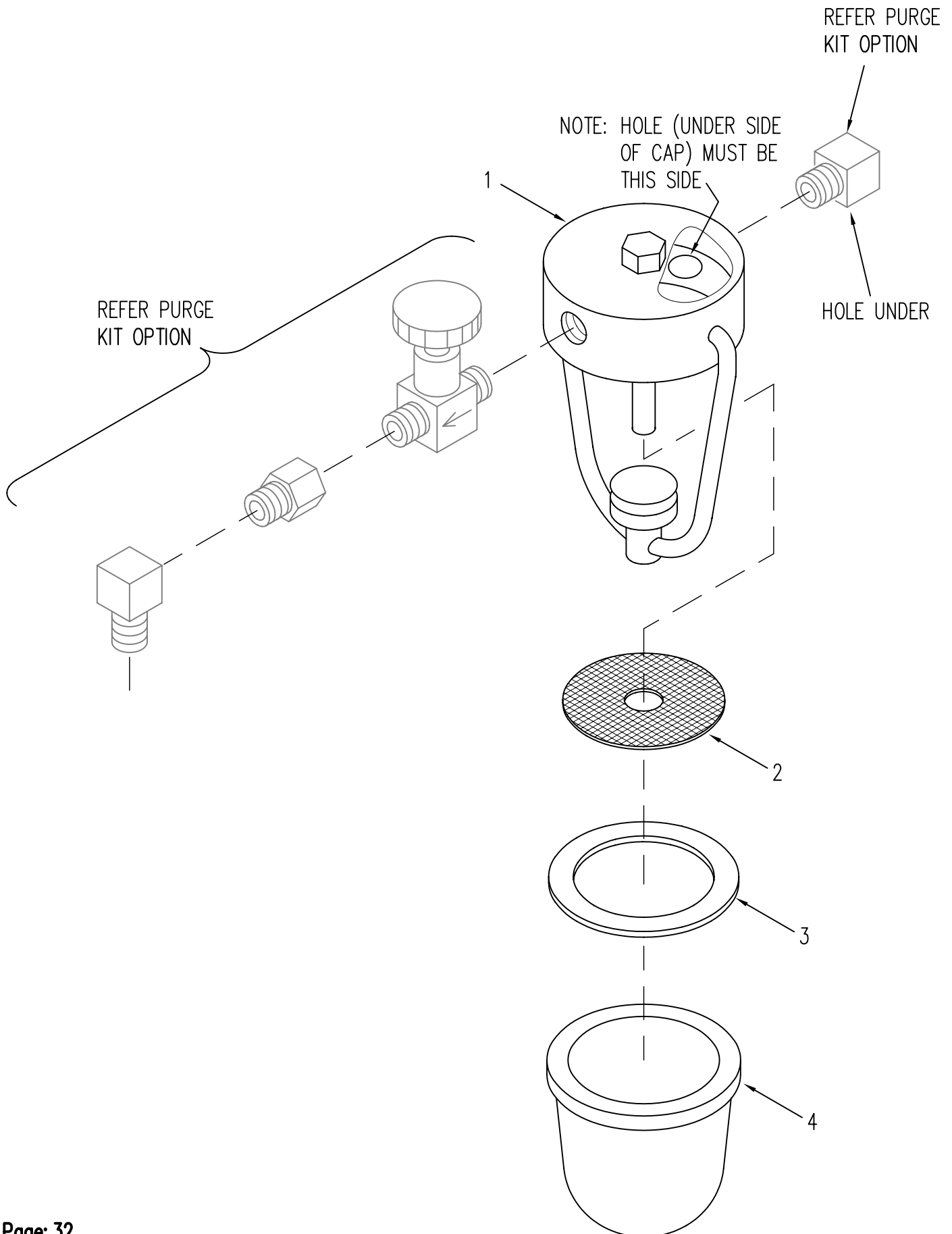



# TRAILCO TRAVELLER

# PARTS LIST

## T 250-2

## MODEL G

**SERIAL No's : 9201 ONWARDS**

SECTION : OILER ASSEMBLY SMALL		PART No. : 7		15-Oct-07
KEY	DESCRIPTION	PART No.	QTY	DWG No.
1	BODY (USE COMPLETE OILER)		1	
2	BRASS SCREEN	793	1	
3	CORK GASKET	794	1	
4	GLASS BOWL	791	1	

PLEASE QUOTE **MODEL** AND **SERIAL NUMBER** OF IRRIGATOR WHEN ORDERING PARTS

Trailco Irrigation (Aust.) Phone: (07) 3260 1828 Fax: (07) 3260 1877

# TRAILCO TRAVELLER T 250-2

MODEL : G

SERIAL No. : 9201 ONWARDS

PART No. : 17952

DATE : 2NOV2005

## POWER TRAIN

REFER CABLE DRUM ASSEMBLY

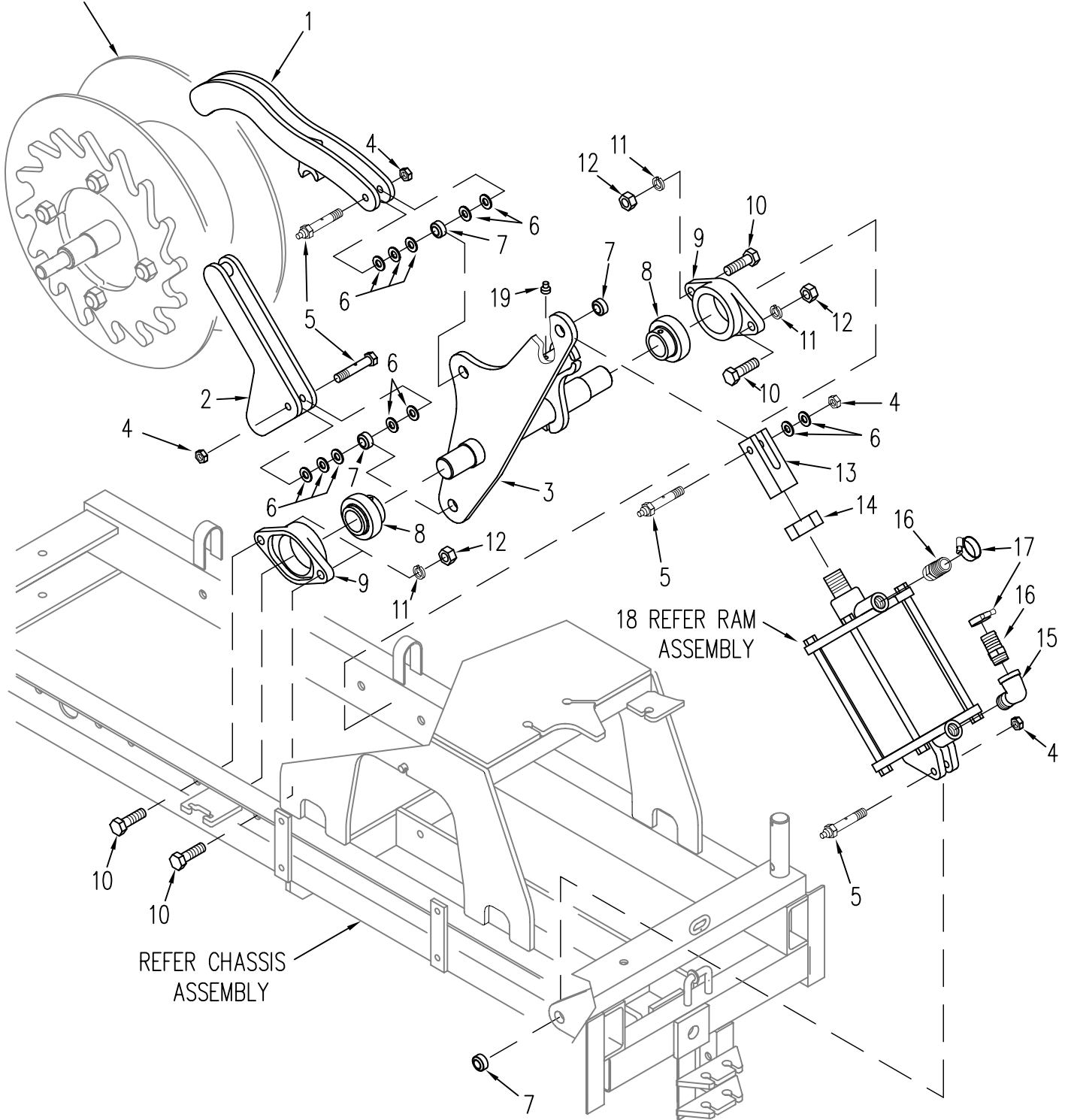

FRONT



# TRAILCO TRAVELLER

# PARTS LIST

## T 250-2

### MODEL G

SERIAL No's : 9201 ONWARDS

SECTION : POWER TRAIN		PART No. : 17952		16-Oct-07
KEY	DESCRIPTION	PART No.	QTY	DWG No.
1	TOP PAWL	633	1	
2	BOTTOM PAWL	635	1	
3	POWER ARM	18059	1	
4	NUT NYLOC ½" UNF	BN180	4	
5	PAWL BOLT	161	4	
6	WASHER FLAT ½" ZP	BW135	12	
7	BEARING	BB159	4	
8	BEARING	18002	2	
9	BEARING HOUSING	18003	2	
10	BOLT M16 X 55MM ZP	18004	4	
11	WASHER SPRING 5/8" ZP	BW110	4	
12	NUT M16 ZP	BN351	4	
13	CLEVIS YOKE	99N	1	
14	LOCK NUT	99K	1	
15	ELBOW	BF41E	1	
16	HOSE TAIL	65	2	
17	HOSE CLIP 1" HOSE SS	BH59	2	
18	RAM ASSEMBLY	18001	1	
19	NIPPLE GREASE ¼" UNF STRAIGHT	B106	1	

PLEASE QUOTE **MODEL** AND **SERIAL NUMBER** OF IRRIGATOR WHEN ORDERING PARTS

Trailco Irrigation (Aust.) Phone: (07) 3260 1828 Fax: (07) 3260 1877

# TRAILCO TRAVELLER T 250-2

MODEL : G

SERIAL No. : 9201 ONWARDS

PART No. : 9450

DATE : 2NOV2005

## PURGE KIT OPTION

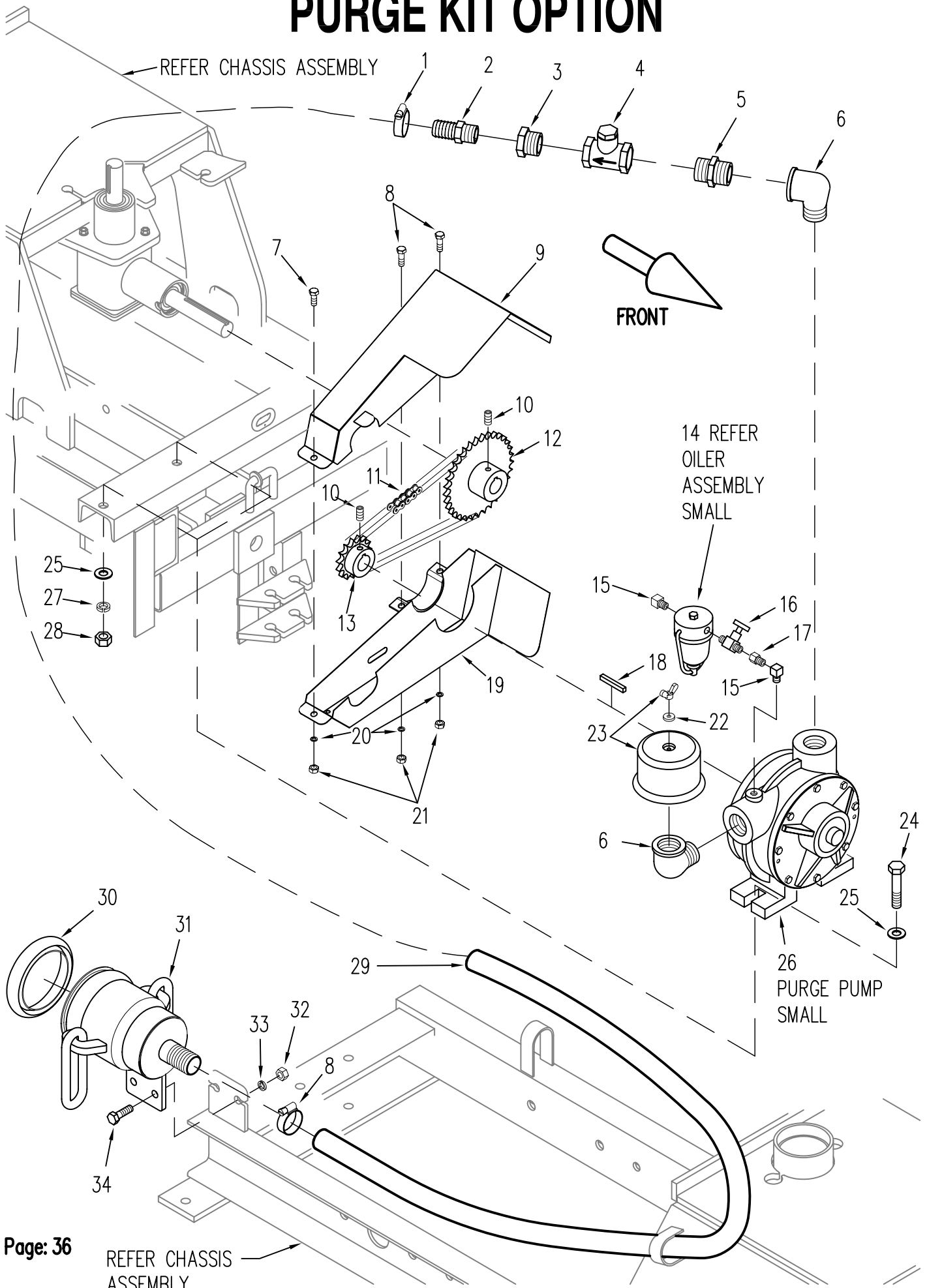



# TRAILCO TRAVELLER

# PARTS LIST

## T 250-2

## MODEL G

SERIAL No's : 9201 ONWARDS

SECTION : PURGE KIT OPTION		PART No. : 9450		15-Oct-07
KEY	DESCRIPTION	PART No.	QTY	DWG No.
1	HOSE CLIP 1" HOSE SS	BH59	2	
2	HOSE TAIL	65	1	
3	BUSH	BF9D	1	
4	VALVE CHECK	BF9B	1	
5	NIPPLE	BF9	1	
6	ELBOW	BF9C	2	
7	BOLT M8 X 16MM HEX ZP	16329	1	
8	BOLT M8 X 25MM HEX ZP	11350	2	
9	PURGE CHAIN COVER - UPPER	18009	1	
10	SET SCREW 5/16" SOC/HD BSW ZP	BN434	2	
11	CHAIN	BS413	1	
12	SPROCKET	BS170G	1	
13	SPROCKET	BS170I	1	
14	OILER ASSEMBLY SMALL	7	1	
15	ELBOW	BF8	2	
16	TAP	BF6	1	
17	ADAPTOR	BF5	1	
18	KEY STEEL 1/4" SQR x 35mm	3K	1	
19	PURGE CHAIN COVER - LOWER	18011	1	
20	WASHER SPRING 5/16"	BW126	3	
21	NUT M8 HEX ZP	16143	3	
22	WASHER AIR CLEANER	18023	1	
23	AIR CLEANER	18008	1	
24	BOLT 1 1/4" X 1/2" BSW ZP	BN116	2	
25	WASHER FLAT 1/2" ZP	BW135	2	
26	PURGE PUMP SMALL	795	1	
27	WASHER SPRING 1/2" ZP	BW118	2	
28	NUT 1/2" BSW ZP	BN117	2	
29	HOSE 1" YELLOW	BH102	1.5m	
30	GASKET	B407	1	
31	PURGE TAIL	693	1	
32	NUT 3/8" BSW ZP	BN146	2	
33	WASHER SPRING 10MM ZP	BN358	2	
34	BOLT 1" X 3/8" BSW ZP	BN123	2	

PLEASE QUOTE **MODEL** AND **SERIAL NUMBER** OF IRRIGATOR WHEN ORDERING PARTS

Trailco Irrigation (Aust.) Phone: (07) 3260 1828 Fax: (07) 3260 1877

# TRAILCO TRAVELLER T 250-2

MODEL : G

SERIAL No. : 9201 ONWARDS

PART No. : 795

DATE : 2NOV2005

## PURGE PUMP SMALL

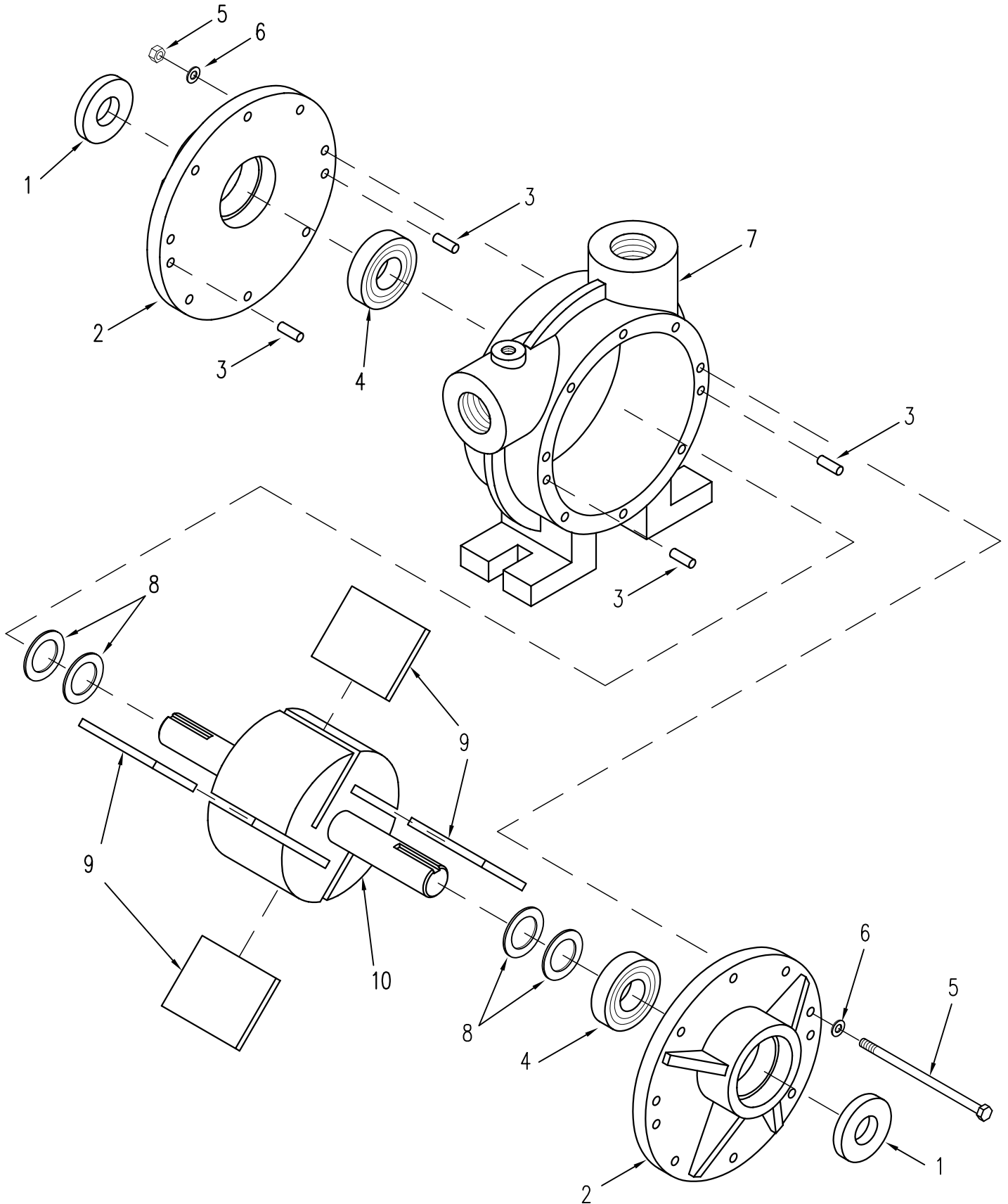





# TRAILCO TRAVELLER

# PARTS LIST

## T 250-2

## MODEL G

SERIAL No's : 9201 ONWARDS

SECTION : PURGE PUMP SMALL		PART No. : 795		15-Oct-07
KEY	DESCRIPTION	PART No.	QTY	DWG No.
1	SEAL	BS3G	2	
2	END CAP	788	2	
3	DOWEL PIN	B3L	4	
4	BEARING	BB3F	2	
5	BOLT & NUT 4½" X ¼" BSW ZP	BN3H	8	
6	WASHER COPPER ¼"	BW100K	16	
7	BODY	790	1	
8	SHIM	BS3E	4	
9	BLADE	3B	4	
10	ROTOR ASSEMBLY LONG	792A	1	

PLEASE QUOTE **MODEL** AND **SERIAL NUMBER** OF IRRIGATOR WHEN ORDERING PARTS

Trailco Irrigation (Aust.) Phone: (07) 3260 1828 Fax: (07) 3260 1877

# TRAILCO TRAVELLER T 250-2

MODEL : G

SERIAL No. : 9201 ONWARDS

PART No. : 18001

DATE : 2NOV2005

## RAM ASSEMBLY

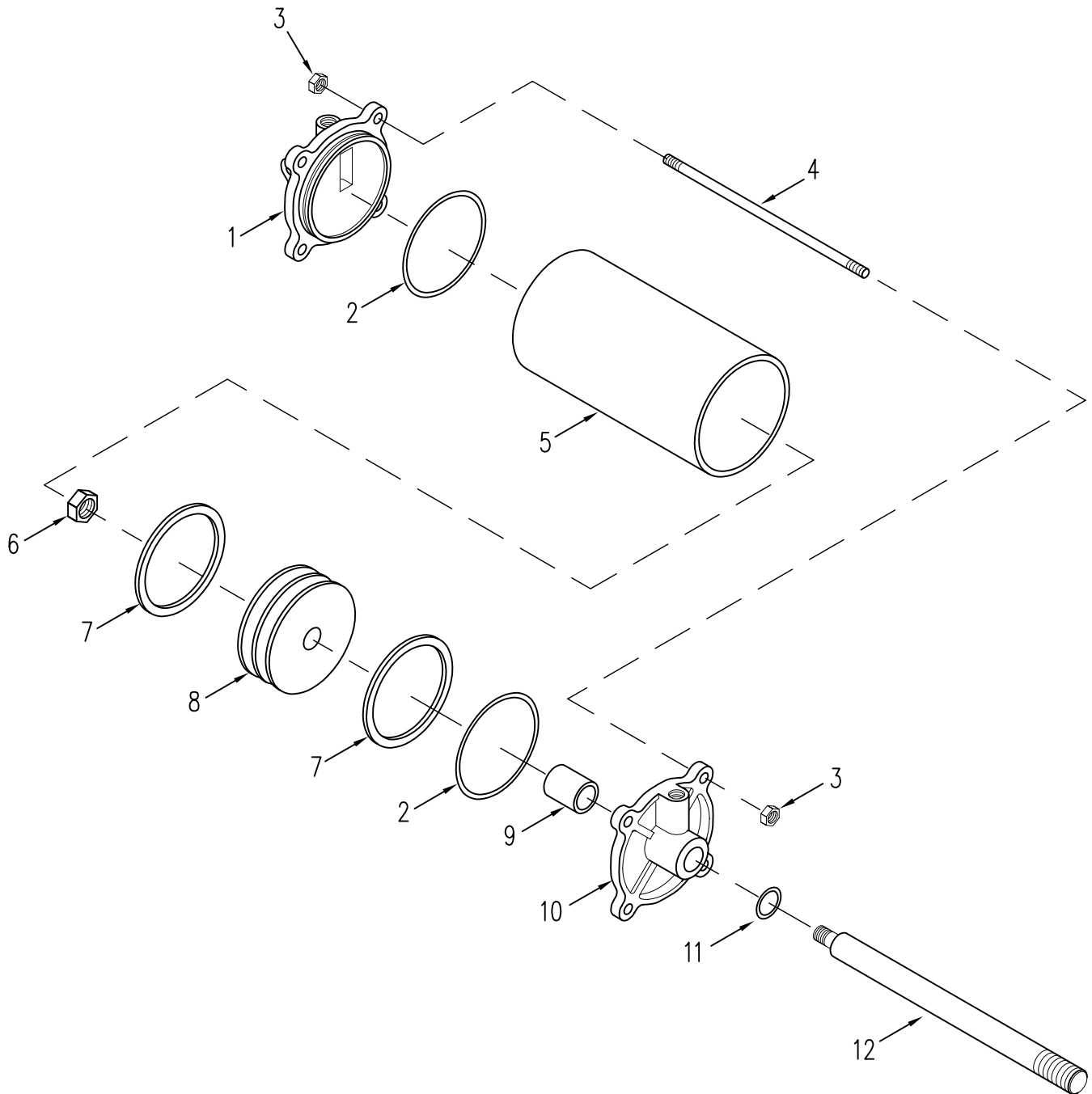



# TRAILCO TRAVELLER

# PARTS LIST

## T 250-2

## MODEL G

**SERIAL No's : 9201 ONWARDS**

SECTION : RAM ASSEMBLY		PART No. : 18001		15-Oct-07
KEY	DESCRIPTION	PART No.	QTY	DWG No.
1	END CAP BOTTOM	1023	1	
2	O-RING	BO99C	2	
3	NUT ½" BSW ZP	BN117	8	
4	TIE BOLT	1019	4	
5	RAM BARREL	736	1	
6	NUT CONELOCK ¾" UNC SS	15956	1	
7	SEAL	BS99A	2	
8	PISTON	460	1	
9	BUSH BRASS	BB99J	1	
10	END CAP TOP	1021	1	
11	SEAL	BS99B	1	
12	PISTON ROD	18000	1	

PLEASE QUOTE **MODEL** AND **SERIAL NUMBER** OF IRRIGATOR WHEN ORDERING PARTS

Trailco Irrigation (Aust.) Phone: (07) 3260 1828 Fax: (07) 3260 1877

# TRAILCO TRAVELLER T 250-2

MODEL : G

SERIAL No. : 9201 ONWARDS

PART No. : 17113

DATE : 2NOV2005

## RISER PIPE ASSEMBLY

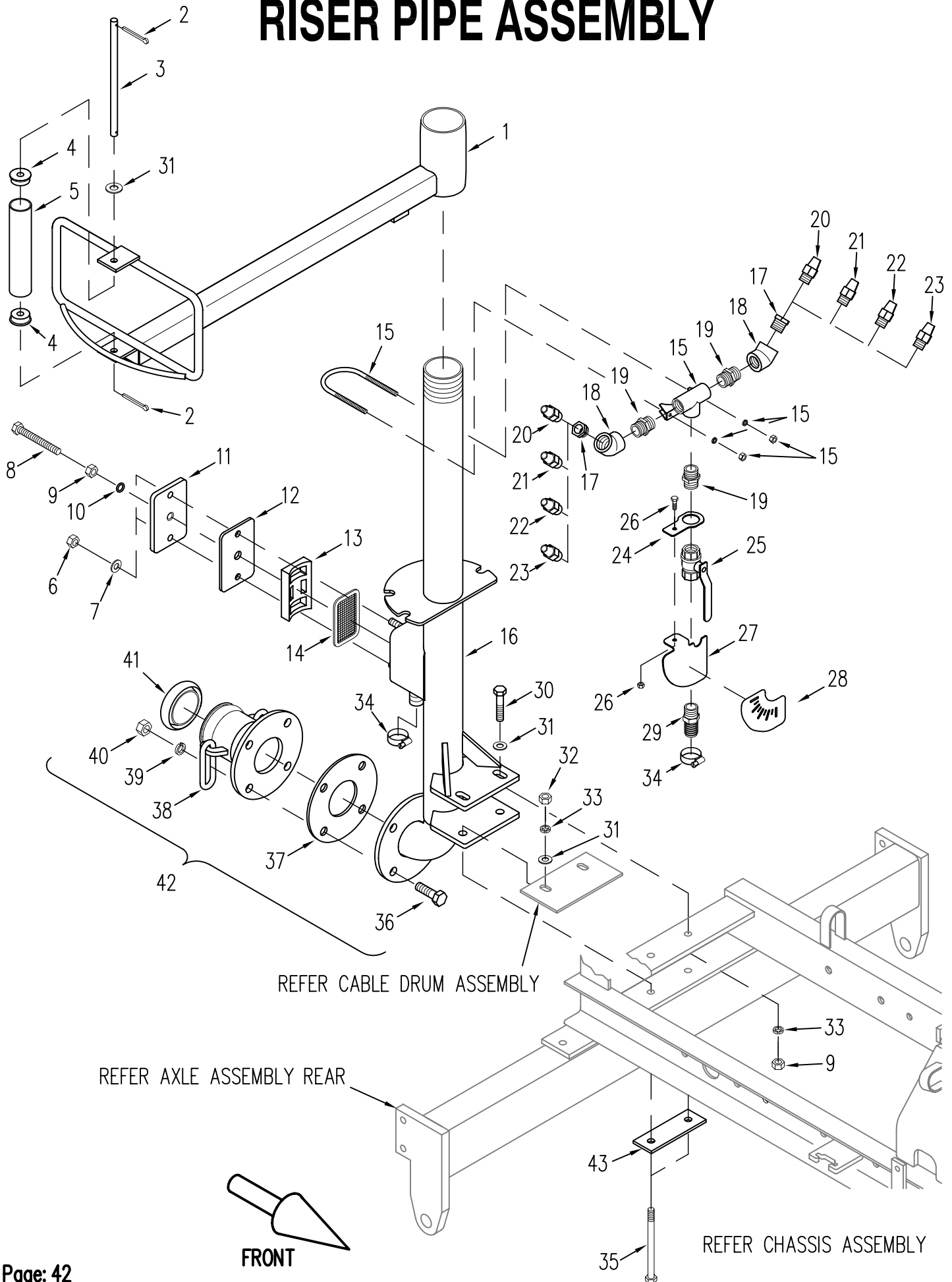



# TRAILCO TRAVELLER

# PARTS LIST

## T 250-2

## MODEL G

**SERIAL No's : 9201 ONWARDS**

SECTION : RISER PIPE ASSEMBLY		PART No. : 17113		15-Oct-07
KEY	DESCRIPTION	PART No.	QTY	DWG No.
1	SIDE LAY ARM FIXED	6862	1	
2	PIN SPLIT STEEL 3.2MM X 32MM ZP	BP133	2	
3	ROLLER PIN	6873	1	
4	BUSH NYLON	6888	2	
5	ROLLER	6849	1	
6	NUT NYLOC 1/2" BSW	BN139	2	
7	WASHER COPPER 1/2" X 7/8" X 1/32"	BW67	2	
8	SET SCREW 4" X 1/2" BSW ZP	BN184	1	
9	NUT 1/2" BSW ZP	BN117	3	
10	O-RING	BO100C	1	
11	COVER PLATE	653	1	
12	GASKET	B69	1	
13	FILTER CLAMP	B218	1	
14	FILTER SCREEN	68	1	
15	EXHAUST T & CLAMP	164	1	
16	RISER PIPE	706G	1	
17	BUSH	BF41D	2	
18	ELBOW	BF402	2	
19	NIPPLE	BF41B	3	
20	EXHAUST JET 3.2MM	B395	2	
21	EXHAUST JET 4MM	B396	2	
22	EXHAUST JET 4.8MM	B397	2	
23	EXHAUST JET 5.6MM	B398	2	
24	KEEPER	17084	1	
25	VALVE BALL	BF40	1	
26	BOLT & NUT 3/4" X 1/4" TANK ZP	17098	1	
27	INDICATOR PLATE	17083	1	
28	STICKER VALVE INDICATOR PLATE	AT24	1	
29	HOSE TAIL	65	1	
30	BOLT 1 3/4" X 1/2" BSW ZP	BN116	2	
31	WASHER FLAT 1/2" ZP	BW135	5	
32	NUT M12 ZP	15830	2	
33	WASHER SPRING 1/2" ZP	BW118	4	
34	HOSE CLIP 1" HOSE SS	BH59	2	
35	BOLT M12 X 180MM ZP	15832	2	
36	BOLT M16 X 40MM HEX ZP	BN346	4	
37	GASKET	A1731	1	
38	WELD BELL	9965	1	
39	WASHER SPRING 5/8" ZP	BW110	4	
40	NUT M16 ZP	BN351	4	
41	GASKET	B407	1	
42	RISER PIPE ASSEMBLY (KEY No's 16,36-41)	706	1	
43	CLAMP PLATE	17859	1	

PLEASE QUOTE **MODEL** AND **SERIAL NUMBER** OF IRRIGATOR WHEN ORDERING PARTS

Trailco Irrigation (Aust.) Phone: (07) 3260 1828 Fax: (07) 3260 1877

# TRAILCO TRAVELLER T 250-2

MODEL : G

SERIAL No. : 9201 ONWARDS

PART No. : 6866

DATE : 2NOV2005

## SIDE LAY ARM TELESCOPIC 65NB

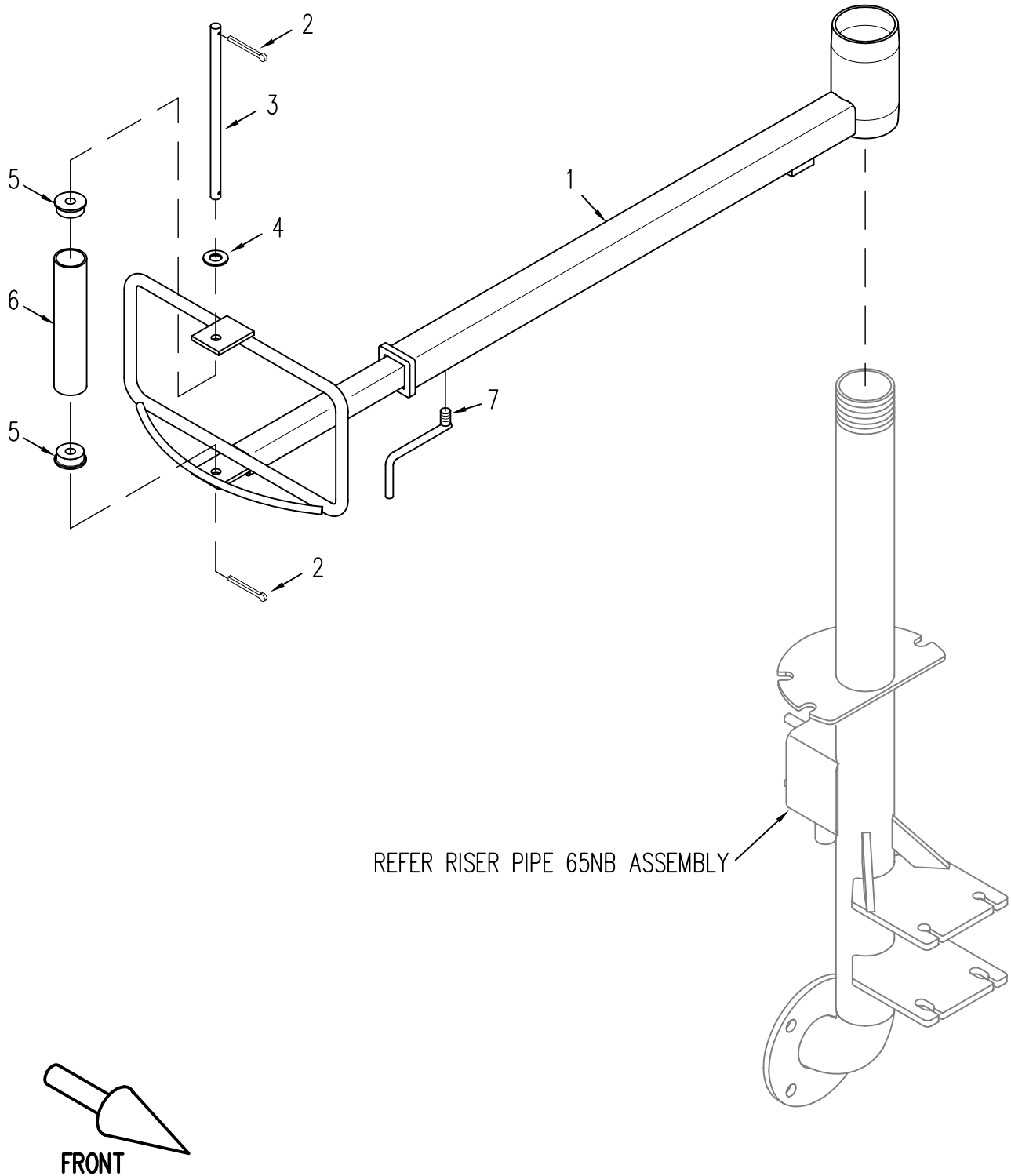



# TRAILCO TRAVELLER

# PARTS LIST

## T 250-2

## MODEL G

SERIAL No's : 9201 ONWARDS

SECTION : SIDE LAY ARM TELESCOPIC 65 NB		PART No. : 6866		15-Oct-07
KEY	DESCRIPTION	PART No.	QTY	DWG No.
1	SIDE LAY ARM TELESCOPIC	6865	1	
2	PIN SPLIT STEEL 3.2MM X 32MM ZP	BP133	2	
3	ROLLER PIN	6873	1	
4	WASHER FLAT 1/2" ZP	BW135	1	
5	BUSH NYLON VERT	6888	2	
6	ROLLER	6849	1	
7	LOCKING SCREW	6872	1	

PLEASE QUOTE **MODEL** AND **SERIAL NUMBER** OF IRRIGATOR WHEN ORDERING PARTS

Trailco Irrigation (Aust.) Phone: (07) 3260 1828 Fax: (07) 3260 1877

# TRAILCO TRAVELLER T 250-2

MODEL : G

SERIAL No. : 9201 ONWARDS

PART No. : 17953

DATE : 2NOV2005

## VALVE TRAIN

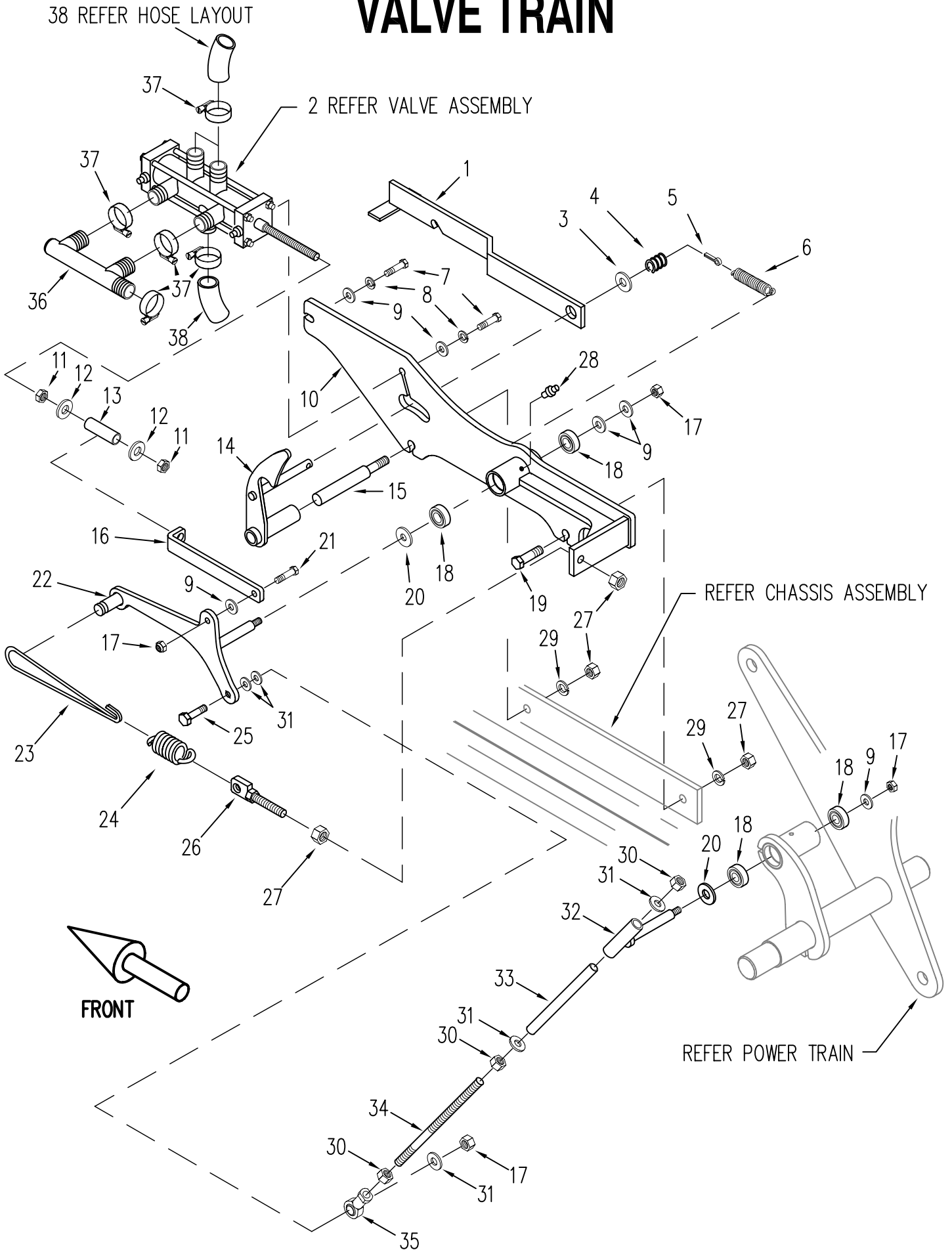





# TRAILCO TRAVELLER

# PARTS LIST

## T 250-2

## MODEL G

SERIAL No's : 9201 ONWARDS

SECTION : VALVE TRAIN		PART No. : 17953		15-Oct-07
KEY	DESCRIPTION	PART No.	QTY	DWG No.
1	SHUT OFF ARM	603	1	
2	VALVE ASSEMBLY ¾"	817	1	
3	WASHER FLAT ½" ZP	BW135	1	
4	SPRING	BX55	1	
5	PIN SPLIT 4MM X 40MM ZP	BP132	1	
6	SPRING	BX56	1	
7	BOLT 1" X 3/8" BSW ZP	BN123	2	
8	WASHER SPRING 10MM ZP	BN358	2	
9	WASHER FLAT 3/8" ZP	BW136	6	
10	VALVE PLATE	18076	1	
11	VALVE SPOOL NUT	102	2	
12	WASHER FLAT 12MM BRIGHT ZP	BW142	2	
13	VALVE SPOOL SLEEVE	15866	2	
14	SHUT OFF LATCH	952	1	
15	LATCH PIN	206	1	
16	VALVE ACTUATING LINK	15860	1	
17	NUT CONELOCK 3/8" BSW ZP	BN138	4	
18	BEARING	BB76	4	
19	BOLT 1¼" X ½" BSW ZP	BN116	1	
20	WASHER FLAT 9/16" X 1 1/8" ZP	BW380	2	
21	BOLT 1½" X 3/8" BSW ZP	BN124	1	
22	VALVE ACTUATING ARM	18082	1	
23	LANYARD	BX58	1	
24	SPRING	BX57	1	
25	BOLT 1¼" X 3/8" BSW ZP	BN120	1	
26	SPRING ANCHOR	18068	1	
27	NUT ½" BSW ZP	BN117	4	
28	NIPPLE GREASE ¼" UNF STRAIGHT	B106	1	
29	WASHER SPRING ½" ZP	BW118	2	
30	NUT 3/8" UNF ZP	100L	3	
31	WASHER FLAT 3/8" X ¼" BRT ZP	BW141	5	
32	VALVE ACTUATING ROD OUTER SLEEVE	15742	1	
33	VALVE ACTUATING ROD INNER SLEEVE	16145	1	
34	VALVE ACTUATING ROD	16147	1	
35	ROD END	B473	1	
36	EXHAUST MANIFOLD	15493	1	
37	HOSE CLIP 1" HOSE SS	BH59	8	
38	HOSE (PER METRE)	BH102	5.5m	

PLEASE QUOTE **MODEL** AND **SERIAL NUMBER** OF IRRIGATOR WHEN ORDERING PARTS

Trailco Irrigation (Aust.) Phone: (07) 3260 1828 Fax: (07) 3260 1877

# TRAILCO TRAVELLER T 250-2

MODEL : G

SERIAL No. : 9201 ONWARDS

PART No. : 817

DATE : 2NOV2005

## VALVE ASSEMBLY 3/4"

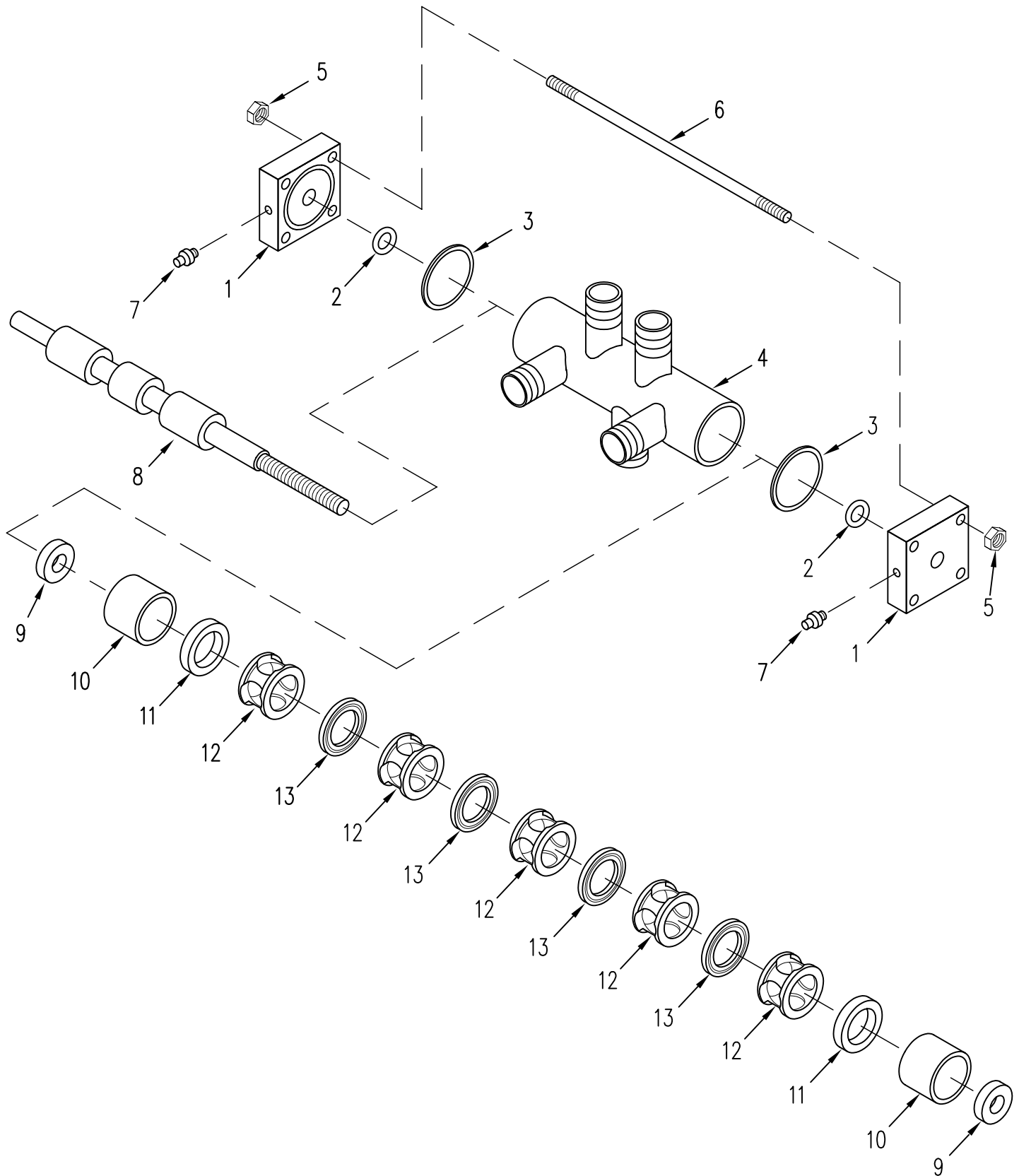



# TRAILCO TRAVELLER

# PARTS LIST

## T 250-2

### MODEL G

SERIAL No's : 9201 ONWARDS

SECTION : VALVE ASSEMBLY 3/4"		PART No. : 817		15-Oct-07
KEY	DESCRIPTION	PART No.	QTY	DWG No.
1	END CAP	820	2	
2	O-RING	BO100C	2	
3	GASKET	B100J	2	
4	VALVE BODY	818	1	
5	NUT 5/16" BSW GAL	BN140	8	
6	TIE BOLT	100N	4	
7	NIPPLE GREASE 1/4" UNF STRAIGHT	B106	2	
8	VALVE SPOOL	100B	1	
9	NYLON BUFFER	B100H	2	
10	PVC SPACER	819	2	
11	NYLON BEARING	100P	2	
12	NYLON SPACER	100Q	5	
13	VALVE SEAL	100M	4	

PLEASE QUOTE **MODEL** AND **SERIAL NUMBER** OF IRRIGATOR WHEN ORDERING PARTS

Trailco Irrigation (Aust.) Phone: (07) 3260 1828 Fax: (07) 3260 1877

**TRAILCO IRRIGATION (AUST.)**  
**A.B.N. 35 480 117 190**  
**STANDARD TERMS OF TRADE**

These following Terms of Trade shall apply to and form part of any contract for the supply of goods or services by Trailco Irrigation (Aust) ("Trailco") to another party ("the customer") including any contract arising from oral acceptance of repeat or further orders from the customer for goods or services the same or similar to those to which this contract applies, and shall terminate, cancel and supercede any previous written or oral agreements and understandings (if any) entered into between Trailco and the customer. These Terms of Trade replace any previous Terms of Trade and may be changed only by writing executed by Trailco's management and the customer.

**1. OFFERS AND ACCEPTANCE**

No quotation given by Trailco shall constitute an offer. An order placed by a customer pursuant to any such quotation is not binding on Trailco unless and until accepted in writing by Trailco.

**2. PURCHASE ORDERS**

When ordering, an official order ("the following order") is to be submitted to Trailco by the customer showing order number, ABN and full description of the goods and services.

**3. PRICES**

The prices charged will be those prices charged in Brisbane at the date of delivery.

**4. PERFORMANCE**

Trailco reserves the right to improve the goods and thereby change the design or specifications thereof without notice to the customer and without incurring any liability to the customer.

**5. INDEMNITY**

Without prejudice to any other rights Trailco may have, the customer shall indemnify Trailco for any loss, damage or expense incurred by Trailco should the customer breach any term of this contract or cancel any order or part thereof after acceptance by Trailco.

**6. DELIVERY**

6.1 Delivery to the customer shall be deemed to be effected when the goods are loaded on the delivery vehicle at Trailco's store.

6.2 Goods supplied by Trailco to the customer shall be at the customer's risk immediately upon delivery to the customer, or into the customer's custody (whichever is the sooner), and the customer shall thereafter insure the goods, at its own expense, against such risks as it thinks appropriate.

6.3 The customer shall be responsible for all costs arising out of or incidental to the delivery of goods to the customer, including freight costs.

6.4 Trailco shall not be liable for any loss or damage (including consequential loss or damage) arising from delay in delivery and/or installation of goods ordered or failure to deliver and/or install the goods as a result of any cause or contingency whatsoever and the customer shall accept and pay for the goods and/or installation notwithstanding the delay or late delivery. Trailco will effect delivery and/or installation as soon as practicable after such causes or contingencies cease to affect delivery and/or the installation.

6.5 The customer shall be responsible for and indemnify Trailco for loss or damage to the goods from time of delivery until paid for in full.

6.6 Where delivery or performance of the goods or services is effected by way of part deliveries or performance, Trailco shall be entitled to invoice the customer for pro rata progress payments in respect thereof.

6.7 Deliveries to third parties may be arranged at the request of the customer subject to acceptance by Trailco. Goods delivered to third parties pursuant to this sub-clause shall be deemed to be delivered to the customer.

**7. ADDITIONAL CHARGES**

Trailco reserves the right to charge the customer for any costs, charges or expenses whatsoever that Trailco may incur on behalf of the customer including, without limiting the generality of the foregoing any costs, charges or expenses incurred as a result of:-

- (a) vehicle or wagon detention (to the extent the same is not caused or contributed to by Trailco);
- (b) demurrage on ships in consequence of any act or omission of the customer; or
- (c) any special requirements or stipulations of the customer agreed to by Trailco but not provided for in the contract.

**8. STORAGE**

If Trailco notifies the customer that the goods are ready for delivery and the customer requests Trailco to hold the goods on its behalf or refuses to accept delivery, such goods will be held by Trailco at the customer's risk and Trailco shall be entitled to charge a reasonable storage fee in respect of the goods.

**9. RETENTION OF TITLE**

9.1 Property in the goods will not pass to the customer until payment by the customer of all monies owing by the customer to Trailco in relation to the supply of goods. Until such time, the customer shall hold the goods as bailee of Trailco.

9.2 Where property in the goods has not passed to the customer, Trailco has the right to enter the premises of the customer, and re-take possession of the goods, and re-sell the goods, notwithstanding the occurrence of the following events:

- (a) if a receiver or a receiver and manager of the customer is appointed;
- (b) if an official manager of the customer is appointed;
- (c) if winding up proceedings are commenced against the customer;
- (d) if, being a natural person, the customer commits an act of bankruptcy, or becomes insolvent or bankrupt.

9.3 The customer shall have the right to sell the goods in the ordinary course of business, as agent for Trailco, and shall have a fiduciary obligation to account to Trailco in relation to the goods, and for the proceeds of any on-sale.

9.4 Until the goods are sold by the customer, the customer shall store the goods separately from its own goods, and in such a manner as to show clearly that they are and remain the property of Trailco.

9.5 Upon sale of the goods, or any part thereof by the customer, the customer shall keep the proceeds of such sale in a separate account on behalf of Trailco and shall apply such proceeds only to the payment of the purchase price to Trailco.

9.6 Notwithstanding clause 13 hereof, the customer shall account to Trailco, in respect of goods which are on-sold by the customer, as soon as the proceeds of sale are received.

9.7 Upon payment by the customer to Trailco of all monies owing to Trailco in respect of all goods supplied by it to the customer, the property in the goods supplied shall pass from Trailco to the customer.

**10. WARRANTIES**

10.1 Trailco warrants to the original purchaser that it will repair or replace at its option, goods manufactured by Trailco or parts thereof free of charge which on return to Trailco with transport and other freight and associated charges prepaid by the customer, shall be acknowledged by Trailco to be defective in material or workmanship. The warranty herein is subject to the following conditions:-

(a) No claim under warranty will be acknowledged where:-

- (i) one (1) year has lapsed from the date of delivery;
- (ii) the goods have been repaired or altered by an entity other than Trailco or Trailco's authorised agent so as, in Trailco's judgement, to affect its stability or efficiency;
- (iii) subject to clause 10.1(a) (ii), the goods are not returned in a state and condition in which they were delivered;

(b) the terms of payment contained in these terms of trade have been complied with:

(c) the goods have been subject to normal use and service.

10.2 Goods supplied by Trailco but not manufactured by Trailco carry their own warranties and Trailco does not accept liability for any defects in such goods.

10.3 Any liability of Trailco under the warranty in clause 10.1 hereof shall not extend to consequential damages, either direct or indirect.

10.4 The warranty in clause 10.1 herein is given in lieu of all other conditions, warranties and undertakings, expressed or implied which might otherwise be binding on Trailco, all of which are, to the extent permitted by law, are expressly excluded and no further responsibility for any consequential damages or any other expenses incurred by the customer will be accepted by Trailco.

10.5 The customer warrants that any goods purchased by the customer are required for the customer's written specifications as described by the customer in the official order and required for no other specifications, whether written or oral.

10.6 Nothing in these Terms of Trade will exclude or modify any condition, warranty, right or liability protected by law where to do so would render any clause of these Terms of Trade void.

**11. LIMITATION OF LIABILITY**

11.1 Pursuant to Section 68A of the Trade Practices Act 1974, clause 11.2 applies in respect of any of the goods or services supplied under this contract which are not of a kind ordinarily acquired for personal, domestic or household use or consumption.

11.2 Liability for breach of a condition or warranty implied into this contract by the Trade Practices Act 1974 other than a condition implied by Section 69 is limited:-

(a) In the case of goods, to any one of the following as determined by Trailco:

- (i) the replacement of the goods or the supply of equivalent goods; or
- (ii) the repair of the goods; or
- (iii) the payment of the cost of replacing the goods or of acquiring equivalent goods; or
- (iv) the payment of the cost of having the goods repaired;

(b) In the case of services, to any one of the following as determined by Trailco:

- (i) the supplying of the services again; or
- (ii) the payment of the cost of having the services supplied again.

**12. GOODS AND SERVICES TAX**

12.1 The Trailco printed List Price is Plus 10% GST.

12.2 Unless otherwise stated, quoted prices do not include GST. Should any other tax, fee, levy or duty imposed by any competent authority be payable on any goods or services supplied by Trailco, such tax, fee, levy or duty will be to the customer's account.

**13. PAYMENT**

13.1 Unless otherwise agreed to, all goods will be supplied on a cash on delivery basis. Trailco shall be entitled to request the payment of a deposit of such amount as it thinks fit. The extension of credit shall be at the absolute discretion of Trailco and where extended, unless otherwise advised in writing, Trailco shall require payment by net cash within 30 days of the end of the month in which the goods were delivered.

13.2 Without in any way limiting Trailco's right to require payment in full on the due date, Trailco may charge interest on an overdue account at the rate of 2.5% above the ANZ Bank's variable Benchmark lending rate as from time to time applicable.

13.3 The customer agrees that Trailco shall be entitled to use the services of a credit agency from time to time to obtain information concerning the customer (and where the customer is a company, its Directors) in order to assess the customer's credit worthiness.

13.4 Should the customer fail to make due payment for any goods or services supplied by Trailco, or being a natural person commits an act of bankruptcy or becomes insolvent or bankrupt, or being a corporation by any act of omission enables the appointment of a scheme manager or trustee, official manager, receiver, receiver and manager or liquidator, Trailco may, without prejudice to other rights it may have, do any of the following:-

- (a) withhold any further deliveries of goods or performance of services required under the contract;
- (b) suspend and/or terminate performance of any other contracts which Trailco has with the customer.

13.5 A statement in writing made up from the books of Trailco and signed by a Manager or Accountant of Trailco, of the moneys owing hereunder in respect of the account of the customer at the date mentioned in such statement, shall be prima facie evidence that such amount is owing.

**14. GOODS RETURNED FOR CREDIT**

14.1 Subject to clauses 14.2 and 14.3, goods listed in Trailco's published Price List or literature may be credited if returned to Trailco within 30 days of delivery, free into Trailco's store in original packing, in an unsoiled, undamaged and reasonable condition and accompanied by Delivery Docket, stating original invoice number, date of purchase and reason for return.

14.2 No goods will be accepted by Trailco for credit if returned to Trailco after a period of 30 days from delivery, unless prior arrangements have been made.

14.3 No goods will be accepted by Trailco for credit if the said goods were made to a special order.

**15. LEGAL CONSTRUCTION**

Unless the parties otherwise agree in writing, these Standard Terms of Trade shall be governed by and construed in accordance with the laws of the State or Territory of acceptance of the customer's order by Trailco.

Terms of Trade applicable 01/07/00

